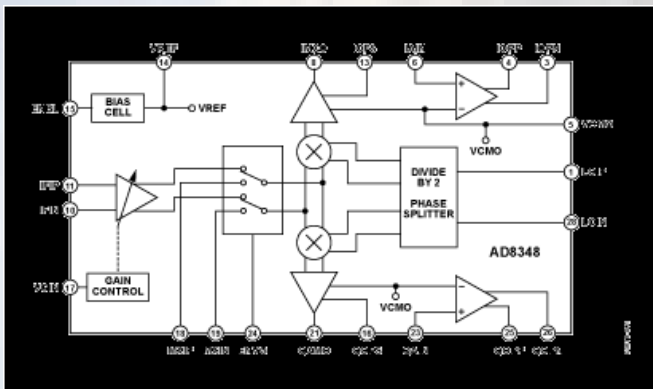

**Aufgabe der Abschlussarbeit im
EIT Bachelorstudiengang****für:** Herrn Gökhan **Mentes****gestellt von:** Prof. Dr.-Ing. Klaus Solbach
Fakultät für Ingenieurwissenschaft - Hochfrequenztechnik**Thema:** **I/Q Comparator-Demodulator Circuit for 7-Tesla MRI Smart Power Amplifier****Beschreibung:**

In a research project, the department develops a high pulse-power amplifier for a 7-Tesla Magnetic Resonance Imaging (MRI) system. The power amplifier employs a high pulse-power final stage with a driver amplifier chain and a Cartesian feedback loop to control amplitude and phase of the generated power signal. The feedback loop is based on the translation of the RF signal at 300 MHz to baseband (zero frequency) with in-phase and quadrature-phase components.

One component of the smart power amplifier to be developed is a circuit that compares a sample of the generated high-power signal to the low-power input signal and that generates a complex (I/Q) base band signal for the analogue control loop from the difference of the two signals.

**Task:**

The task of the thesis is to build such a comparator circuit with a specially designed sampling circuit using passive components and available active electronic circuits, in particular digital controlled attenuator circuits DAT-31R5 and the AD8348 I/Q demodulator circuit. The electronic circuits can be designed following examples given by the manufacturer data sheets. The sampling circuit may employ the concept of a broadband voltage probe as used with oscilloscopes with an additional diode limiter circuit as a protection against high peak power.

In particular the task entails the following steps:

- Design and build two versions of a voltage sampling circuit providing an adjustable step-down ratio of 1000V to 1V and 100V to 1V into a 50 Ohm load at 300 MHz.
- Test the sampling circuit regarding the voltage step-down ratio and its adjustability and voltage handling capability.
- Design a circuit layout and assemble (after production of the PCB at our workshop) the RF attenuator using the DAT-31R5 with a DIP switch bank for manual attenuation setting and test the functionality of the circuit.
- Design a circuit layout and assemble (after production of the PCB at our workshop) the I/Q demodulator circuit using the AD8348.
- Test the functionality of the circuit and measure the resulting transfer characteristic of baseband voltage versus RF input voltage.
- Combine the layouts of the sampling circuit (100V to 1V), attenuator and I/Q demodulator using as little as possible board area.
- Assemble the circuit (after fabrication of the PCB) and demonstrate the functionality using a high-power amplifier and a continuous and pulsed RF generator at 300 MHz.

At the end of the work, a public presentation of results is to be given.