

The background of the slide is a photograph of a 7-tesla MRI scanner in a clinical setting. The scanner is a large, cylindrical machine with a patient bed extending from its center. The room is brightly lit, and there are shelves with various items on the right side. The text is overlaid on this image.

Investigation of a Voltage Probe in Microstrip Technology

(Specifically in 7-tesla MRI System)

By : Mona ParsaMoghadam

Supervisor : Prof. Dr. Ing- Klaus Solbach

April 2015

Outline

- **Introduction**
 - Thesis work scope
 - MRI system
 - RF Power Amplifier / Cartesian Feedback Circuit
- **Inaccuracy in Probing Voltage**
 - Parasitic Elements
 - Electromagnetic coupling and induced voltage
- **Electromagnetic Simulation**
- **Circuit Simulation**
- **Measurements**
- **Summary and Conclusion**

Outline

- 
- **Introduction**
 - Thesis work scope
 - MRI system
 - RF Power Amplifier / Cartesian Feedback Circuit
 - Inaccuracy in Probing Voltage
 - Parasitic Elements
 - Electromagnetic coupling and induced voltage
 - Electromagnetic Simulation
 - Circuit Simulation
 - Measurements
 - Summary and Conclusion

Thesis work scope

Accuracy of probing signals is so important in some applications !

- **Specifically in MRI systems, the deviation from the expected values in RF signal (amplitude or phase) can be dangerous for the patient since high amount of power might be induced into the body.**
- **Also obtaining correct amplitude and phase of the RF signal is a very important factor for the image quality.**

Different Part of MRI System

- Magnet :

Producing a constant magnetic field (B_0)

- Gradient Coil

Producing a ramp signal for B_0 magnetic field

- RF Coil

Generates B_1 field by time varying RF signal

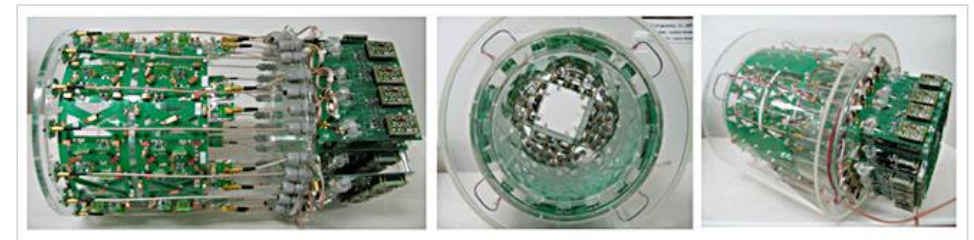
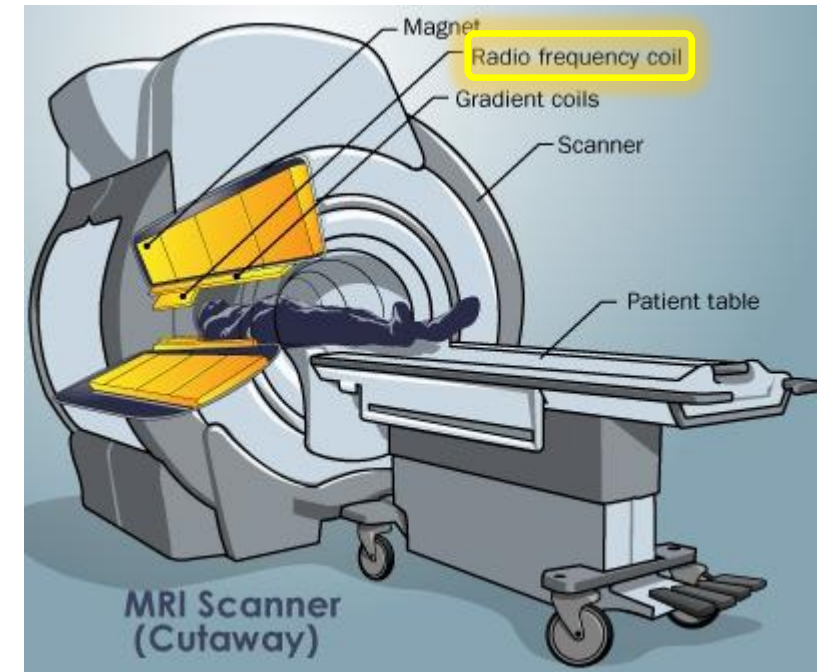

Cartesian Feedback Circuit for Current Coil Controlling

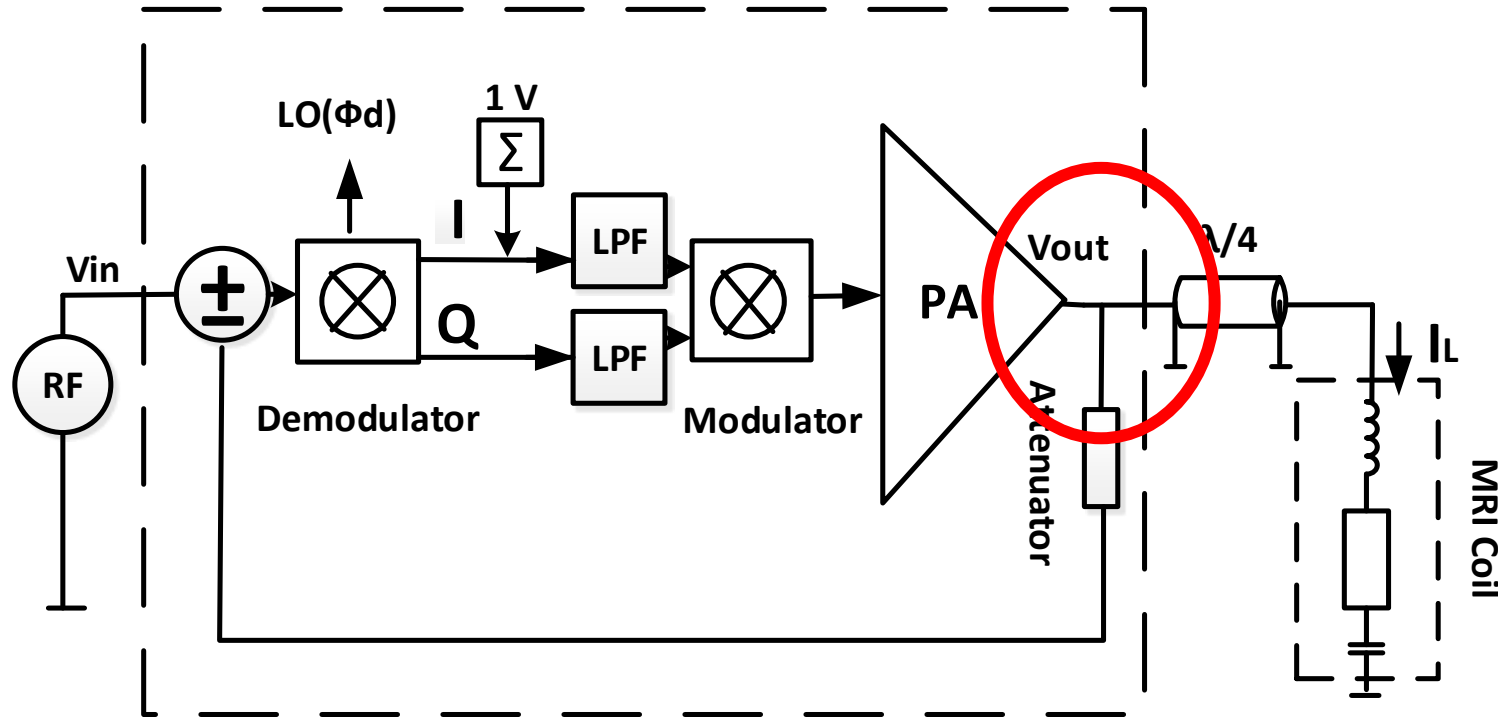

- Different bodies have various impedances
- When patient body is placed in MRI scanner impedance variation happens

Probing Voltage at Output of Amplifier

- Accuracy of probed voltage is important since
 - The probed voltage will be compared with the input RF signal for correcting the output RF signal which goes to the RF coil
 - The voltage at the output of the power amplifier represents the current in RF coil ($\frac{\lambda}{4}$ distance)

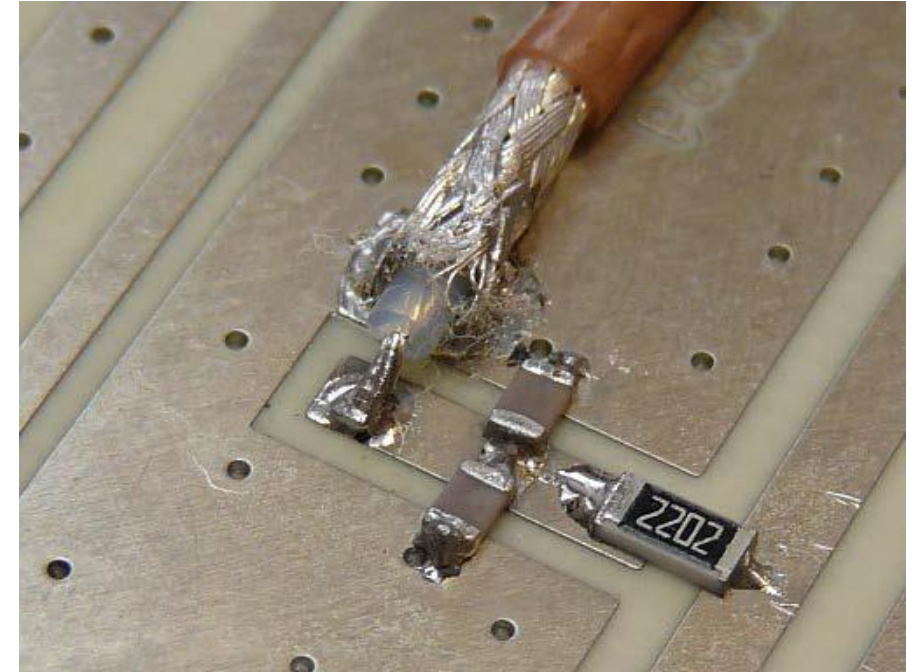

Probed Voltage level

The signal power at the output of the power amplifier is about 1 kW .

The voltage on the 50 Ω transmission line is 223.60 volt .

From voltage divider formula :

$$\text{Probed voltage} = \frac{50 \Omega}{22 \text{ k}\Omega + 50 \Omega} \cdot V_{line} = 506 \text{ mV}$$

Some phenomenon cause inaccuracy in probing voltage.

Outline

- Introduction
 - Thesis work scope
 - MRI system
 - RF Power Amplifier / Cartesian Feedback Circuit
- ➔ • **Inaccuracy in Probing Voltage**
 - **Parasitic Elements**
 - **Electromagnetic coupling and induced voltage**
- Electromagnetic Simulation
- Circuit Simulation
- Measurements
- Summary and Conclusion

Frequency dependency

Parasitic elements in SMD components

- Equivalent circuit for resistor

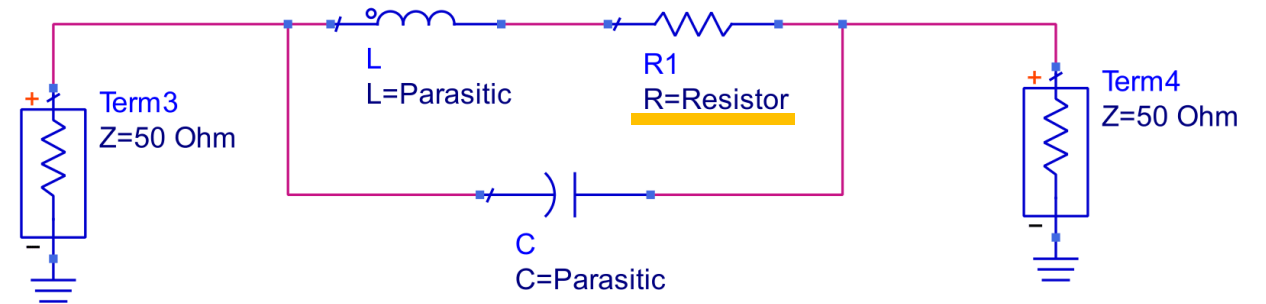

- Equivalent circuit for capacitor

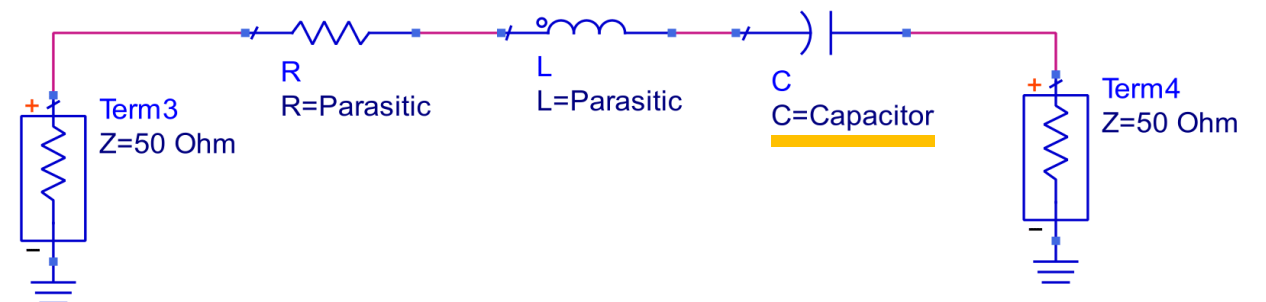

Parasitic elements cause frequency dependency

The internal parasitic capacitance of the attenuator (22kΩ resistor) causes frequency dependency in the probed signal .

The parasitic capacitance of a 22kΩ SMD 1206 is measured as 58 fF .

The reactance of this capacitance in Larmor frequency (298 MHz) is:

$$X_c = \frac{1}{\omega \cdot C} = \frac{1}{2\pi f C}$$

$$X_c = \frac{1}{2\pi \cdot 298 \cdot 10^6 \cdot 58 \cdot 10^{-15}} = 9.208 \text{ k}\Omega$$

Cancellation of parasitic effects

- Same concept like it is used in oscilloscope voltage probe

$$V_S = \frac{Z_1}{Z_1 + Z_2} V_O$$

$$Z_1 = R_S \parallel C_S \parallel C_C$$

$$Z_2 = R_P \parallel C_P$$

if

$$R_P \cdot C_P = R_S \cdot (C_S + C_C)$$

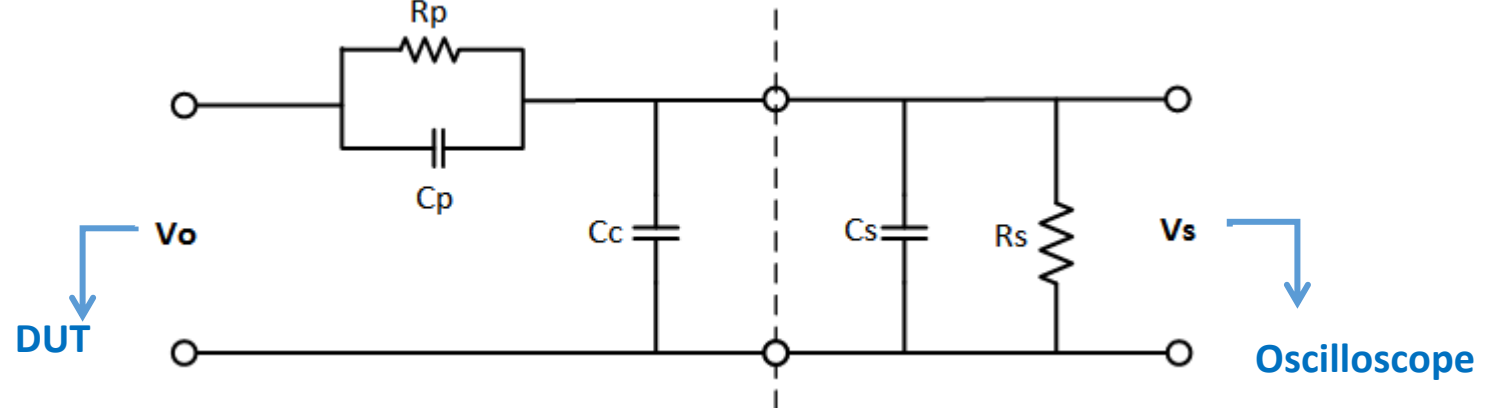

is valid, the relationship between V_O and V_S will become frequency-independent.

Cancelling the effect of parasitic capacitance

$$R_p = 22 \text{ k}\Omega$$

$$C_p = 58 \text{ fF}$$

$$R_S = 50 \Omega$$

$$C_{shunt} = \frac{22 \text{ k}\Omega \cdot 60 \text{ fF}}{50 \Omega} = 25.5 \text{ pF}$$

The nearest standard value to 25.5 pF is 22 pF .

→ Effect of parasitic capacitance can be eliminated by adding a 22 pF shunt capacitance to the structure

Electromagnetic coupling

- Faraday's Induction law predicts how changing magnetic flux through surface S induces emf in any boundary path of that surface.

$$\text{Electromotive force} = - \frac{d}{dt} \int_S \underbrace{\vec{B} \cdot \vec{n} da}_{\text{Magnetic Flux}}$$

→ Difference between probed signal when signal travels in different direction on high-power line is cause by magnetic coupling.

The magnetic coupling induces the voltage on the line which is not negligible !

There are various factors that affect the electromagnetic fields on the structure.
Some of them are :

- Relative permittivity of substrate (ϵ_r)
- Substrate height
- Size of ground area between lines

→ Not so easy to predict electromagnetic field behavior in different part of the structure.

The best way is to run electromagnetic simulation.

Outline

- Introduction
 - Thesis work scope
 - MRI system
 - RF Power Amplifier / Cartesian Feedback Circuit
- Inaccuracy in Probing Voltage
 - Parasitic Elements
 - Electromagnetic coupling and induced voltage
- ➔ • **Electromagnetic Simulation**
 - Circuit Simulation
 - Measurements
 - Summary and Conclusion

Building up the Model in the Simulation Tool (Empire XPU)

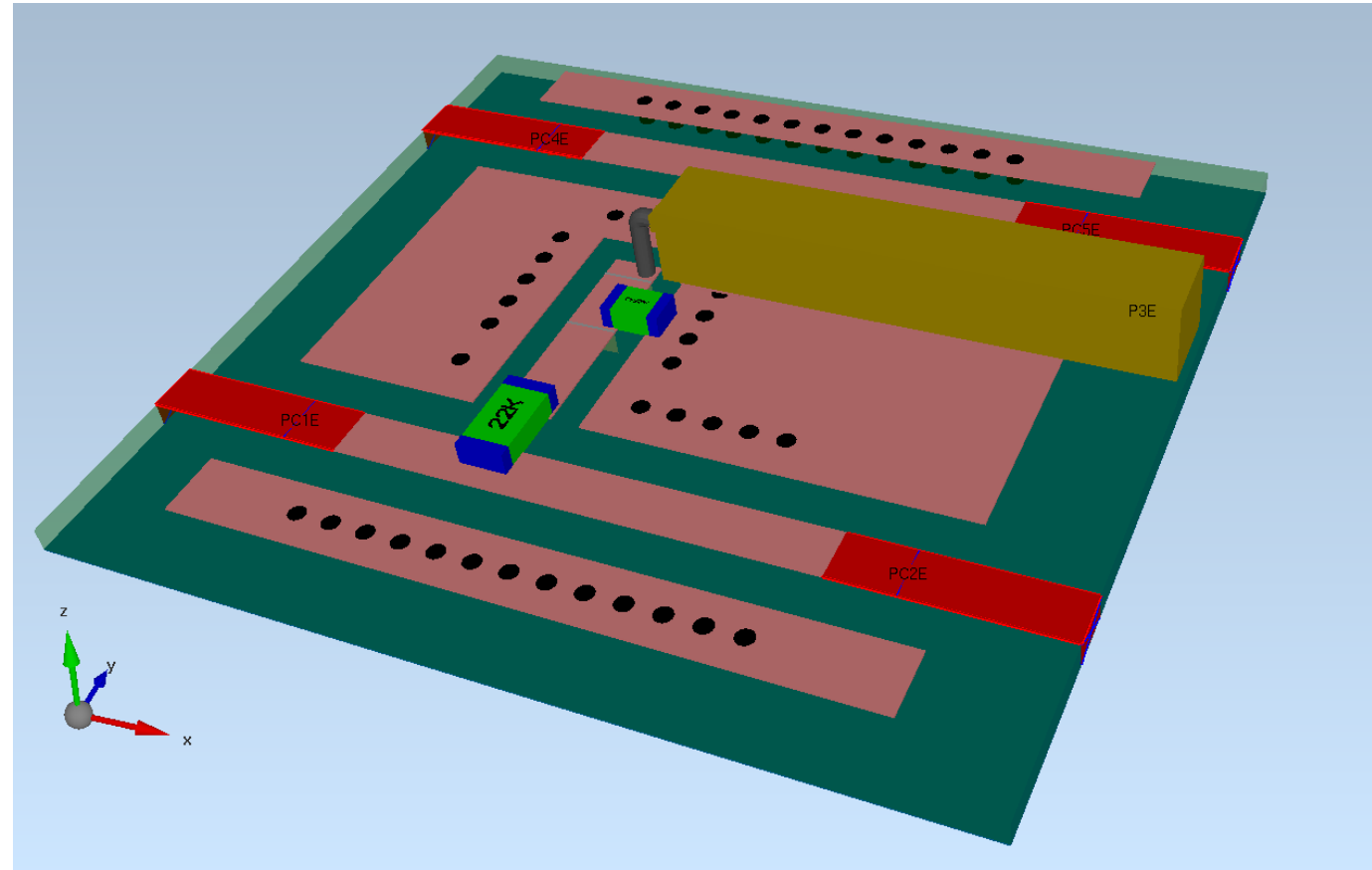

Simulation results with and without shunt capacitor

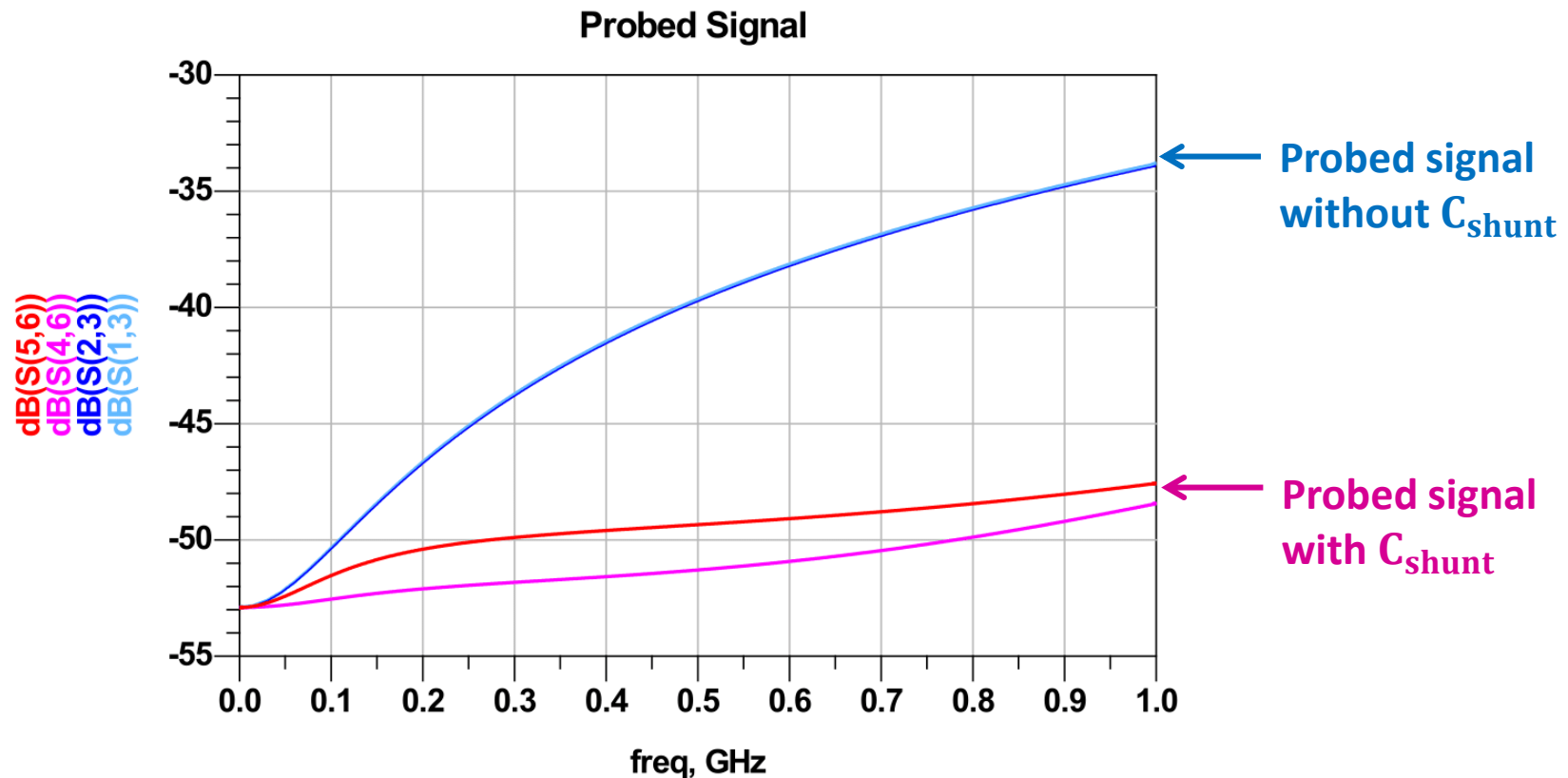

Simulation Results:

Comparison between using 2 parallel 11pF capacitor and one 22pF

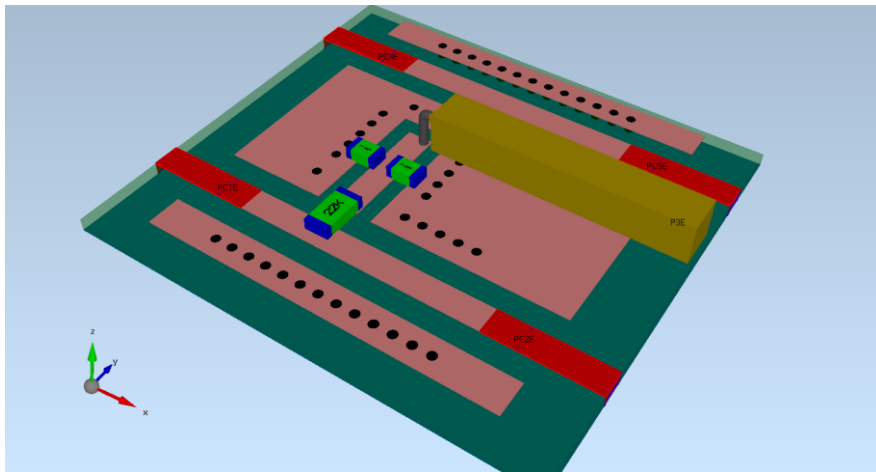

$\text{dB}(S(5,6))$
 $\text{dB}(S(4,6))$
 $\text{dB}(S(2,3))$
 $\text{dB}(S(1,3))$

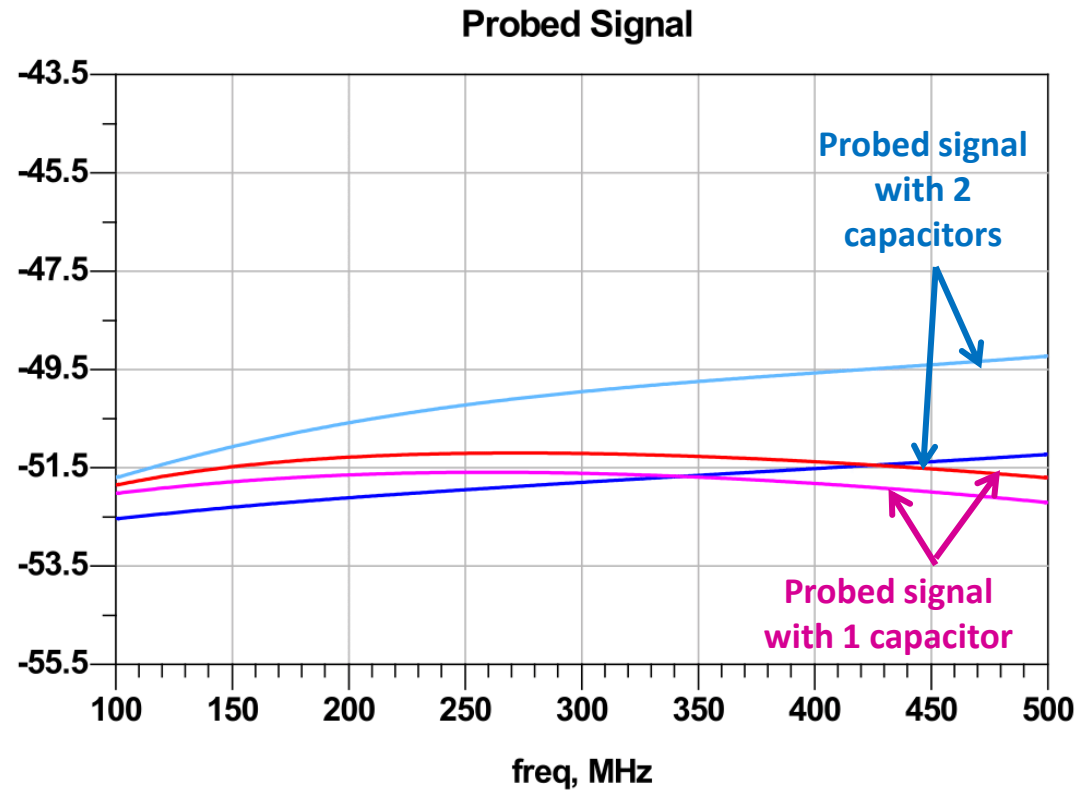

Simulation results for different arrangements

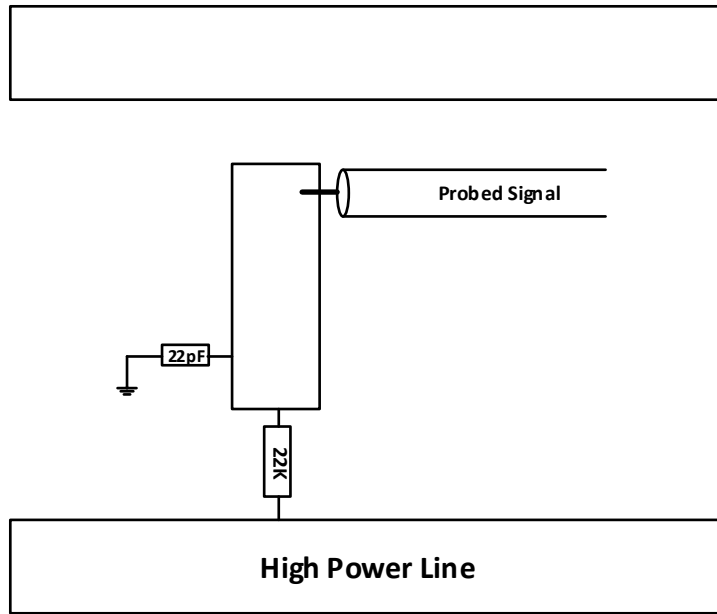

[1]

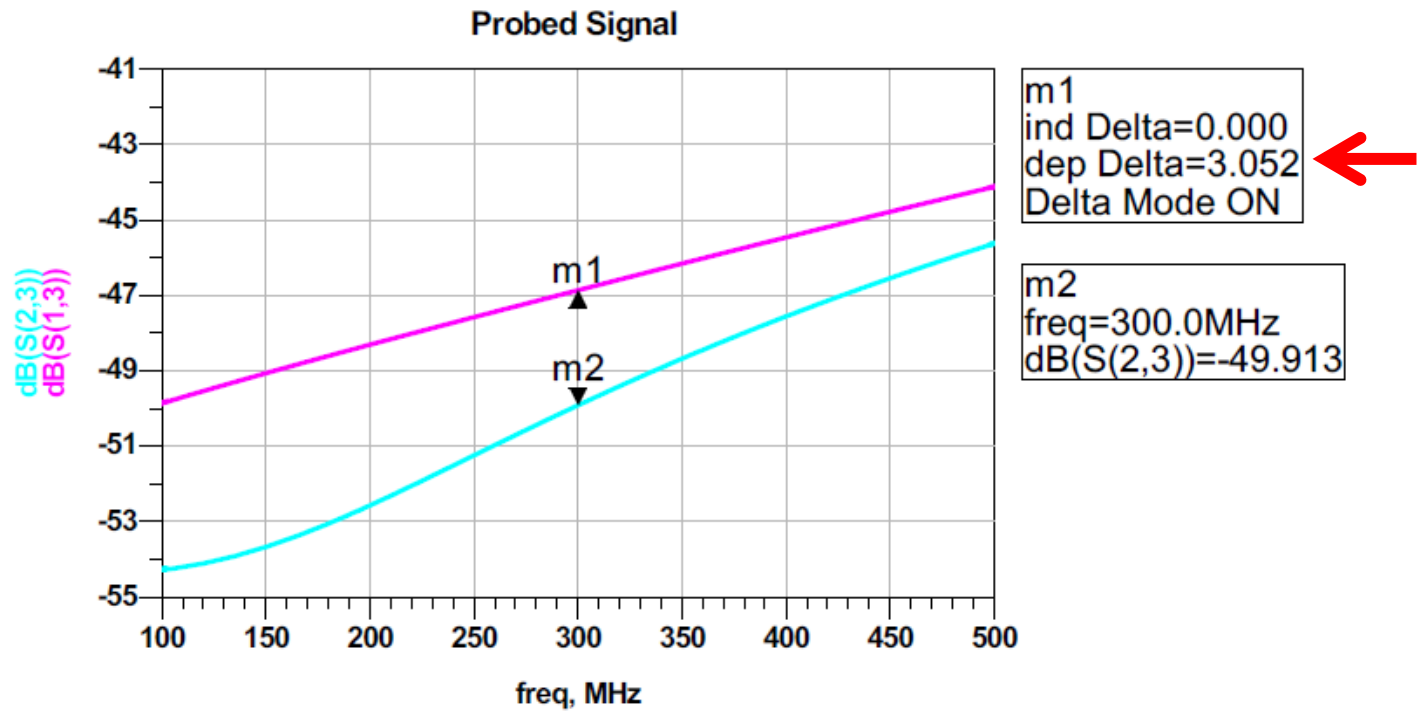

Simulation results for different arrangements

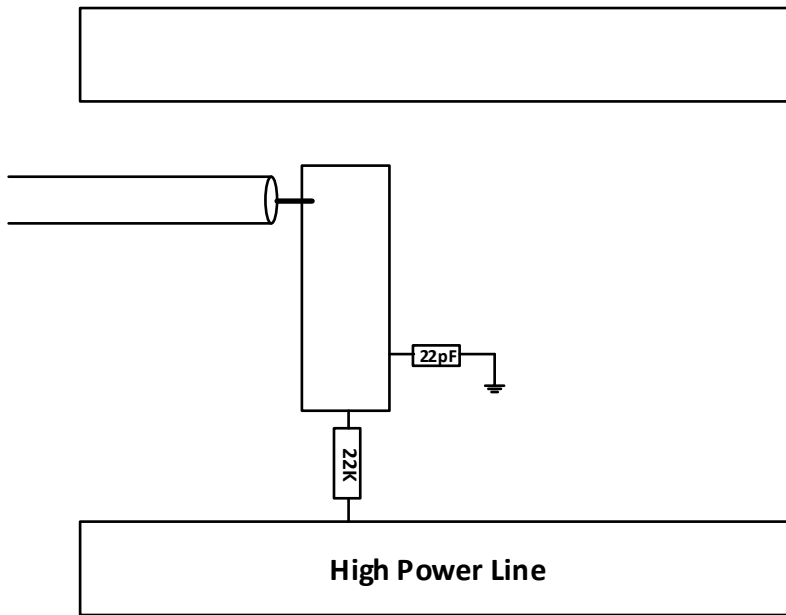

[2]

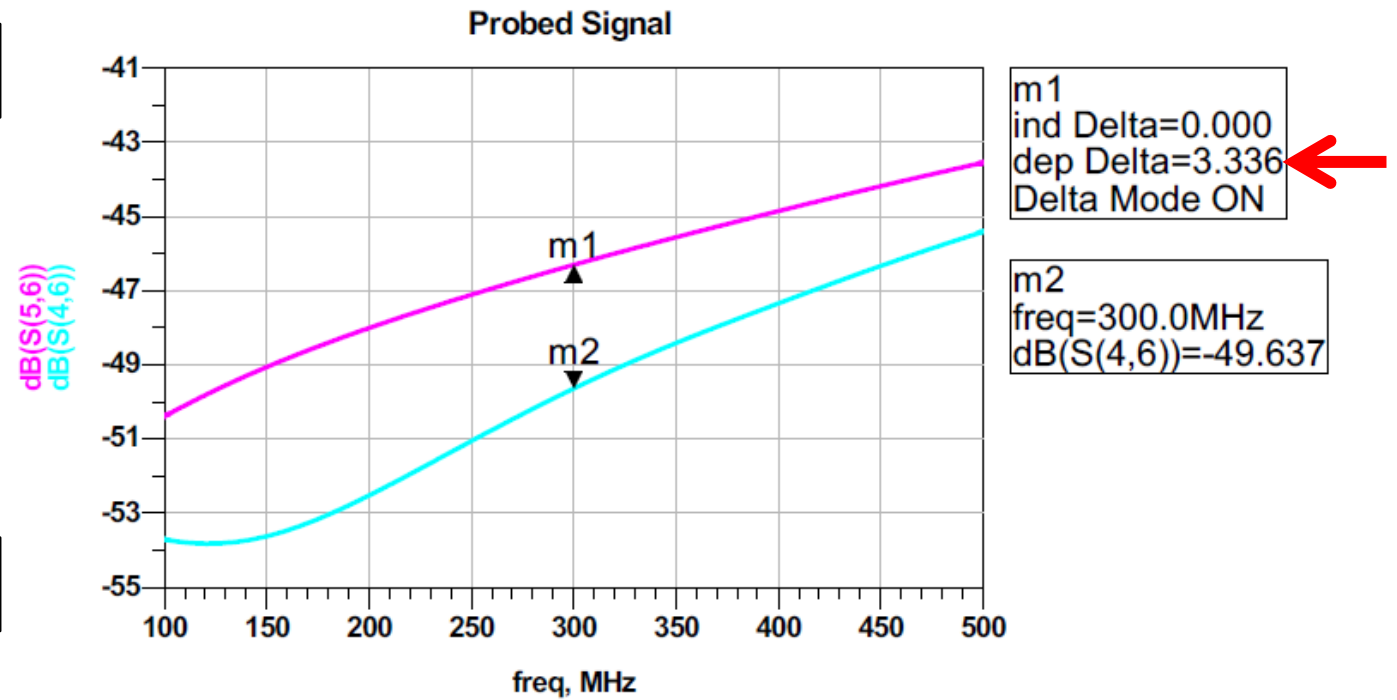

Simulation results for different arrangements

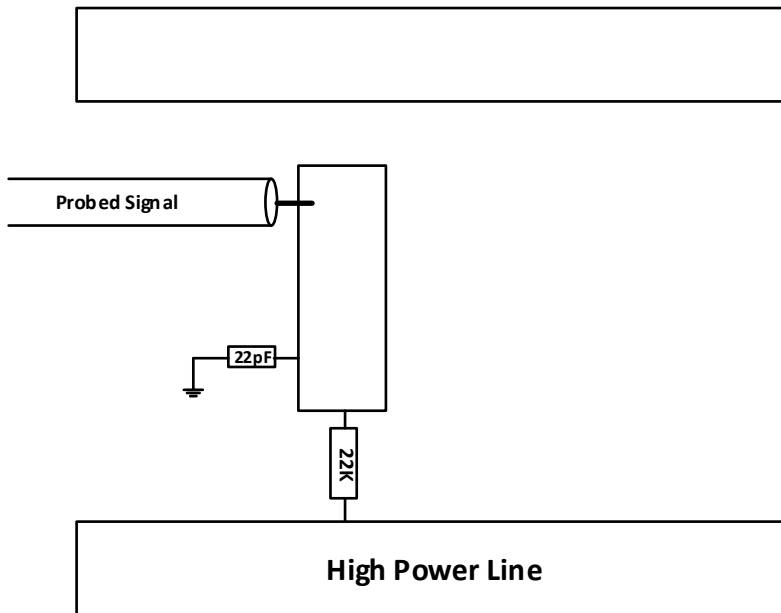

[3]

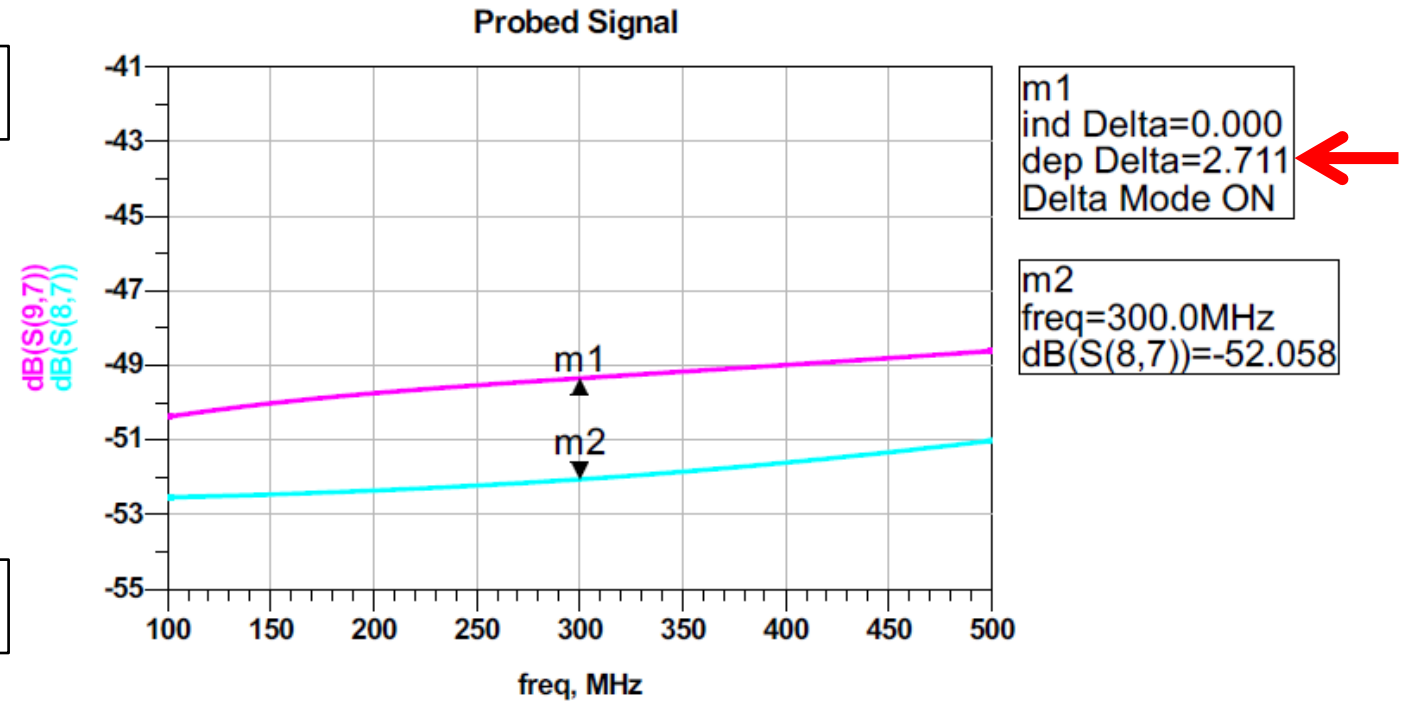

Simulation results for different arrangements

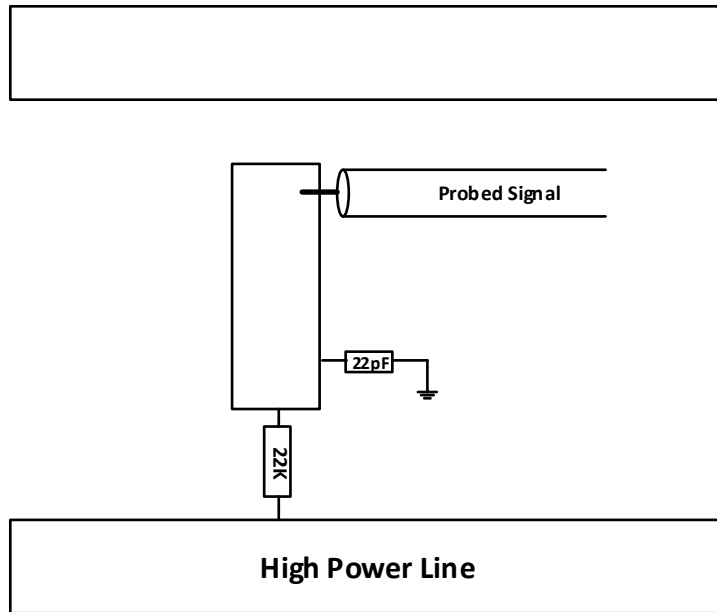

[4]

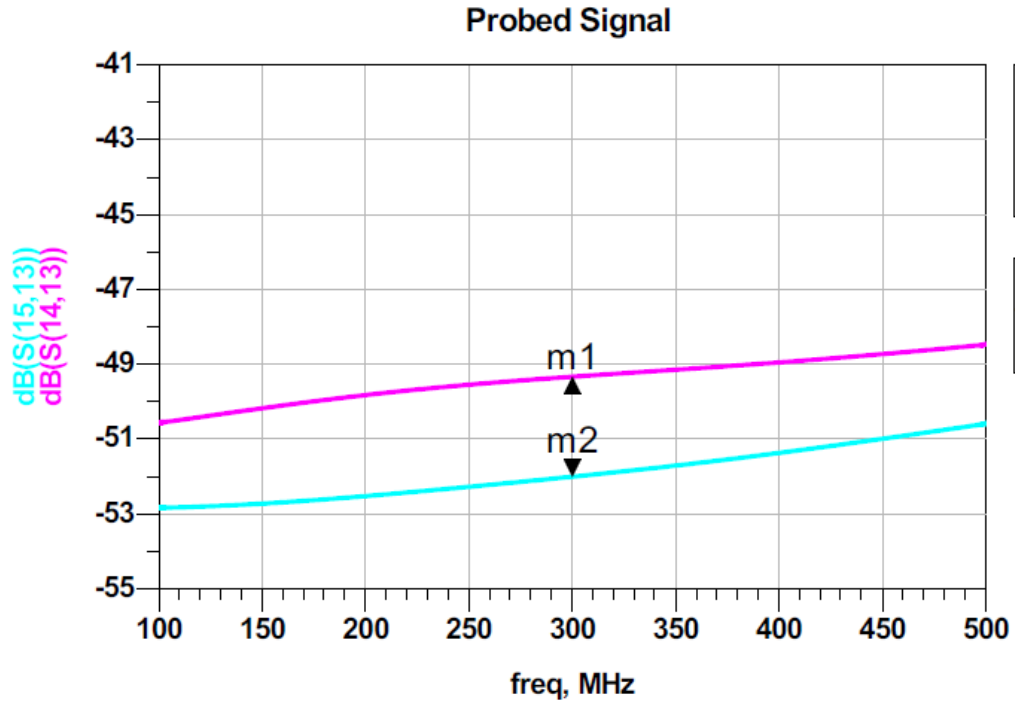

m1
ind Delta=0.000
dep Delta=2.673
Delta Mode ON

m2
freq=300.0MHz
dB(S(15,13))=-52.004

Reducing induced voltage by shifting capacitor near to coax cable

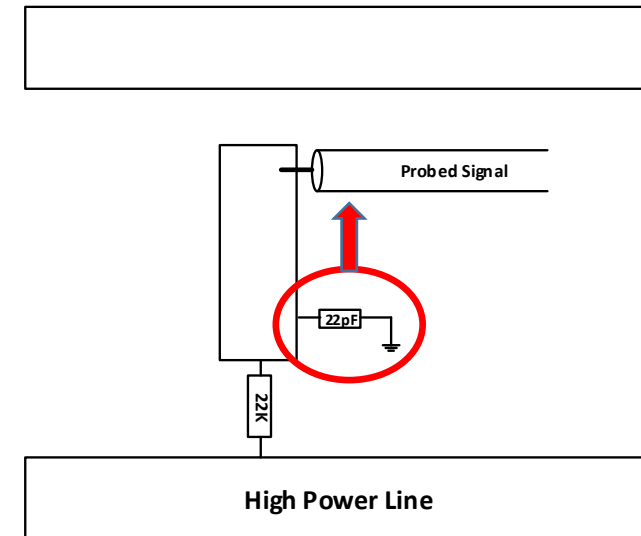
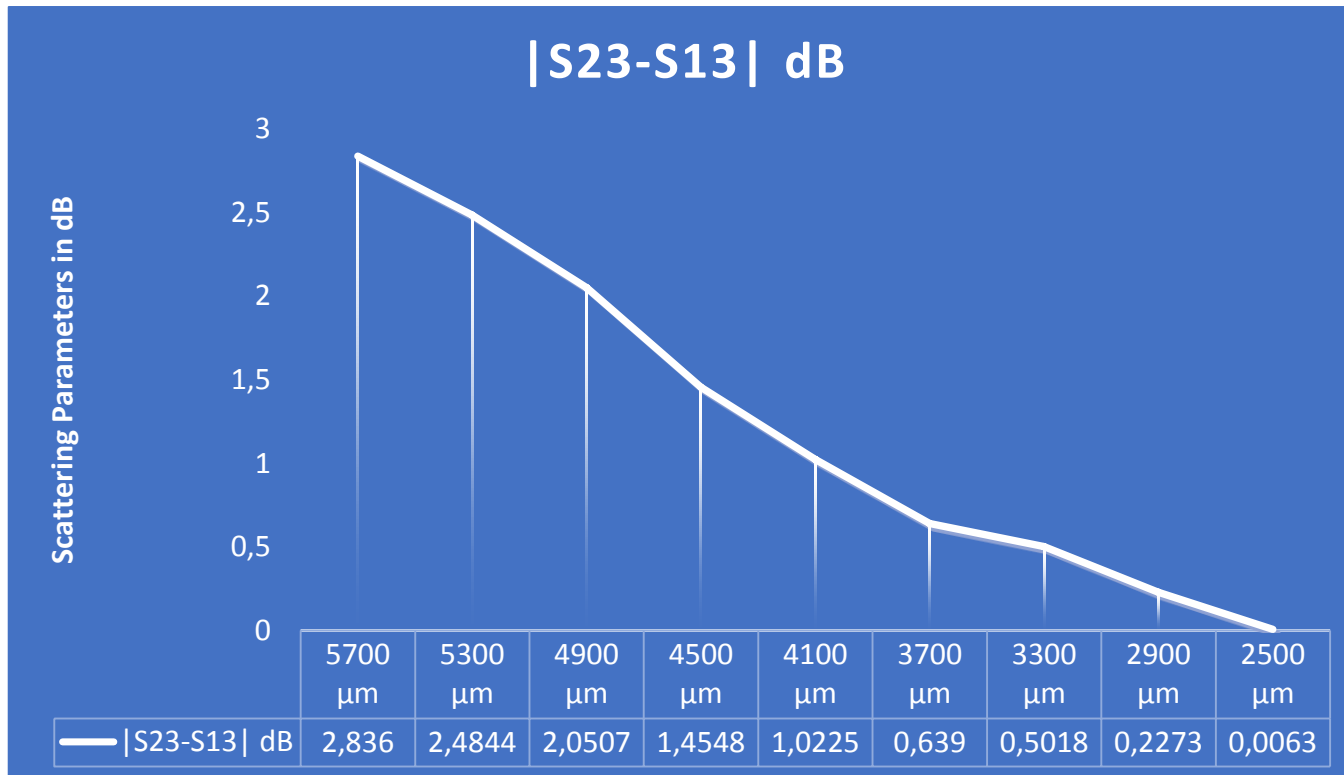

[4]

Probed signal near and far from high-power line :

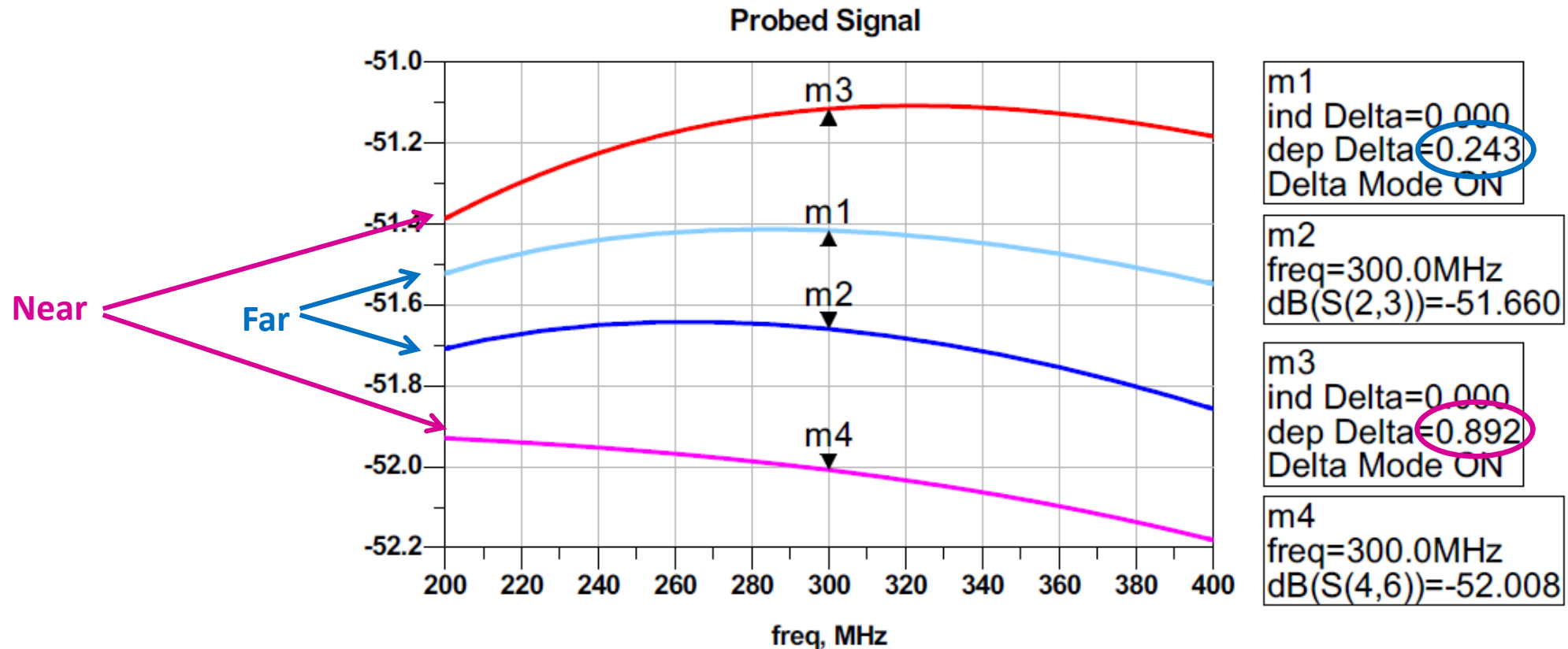

Conclusion of EM Simulation

- The loop that is made by shunt capacitor and coax cable is the critical area. The magnetic flux pass through this area, induce emf on the line.
- According to Faraday's induction law the induced emf can be decreased by
 - Minimizing the surface area that magnetic flux goes through
 - Getting far from high-power line for reducing magnetic filed strength

Outline

- Introduction
 - Thesis work scope
 - MRI system
 - RF Power Amplifier / Cartesian Feedback Circuit
- Inaccuracy in Probing Voltage
 - Parasitic Elements
 - Electromagnetic coupling and induced voltage
- Electromagnetic Simulation
- ➔ • **Circuit Simulation**
- Measurements
- Summary and Conclusion

Equivalent Circuit without considering magnetic coupling

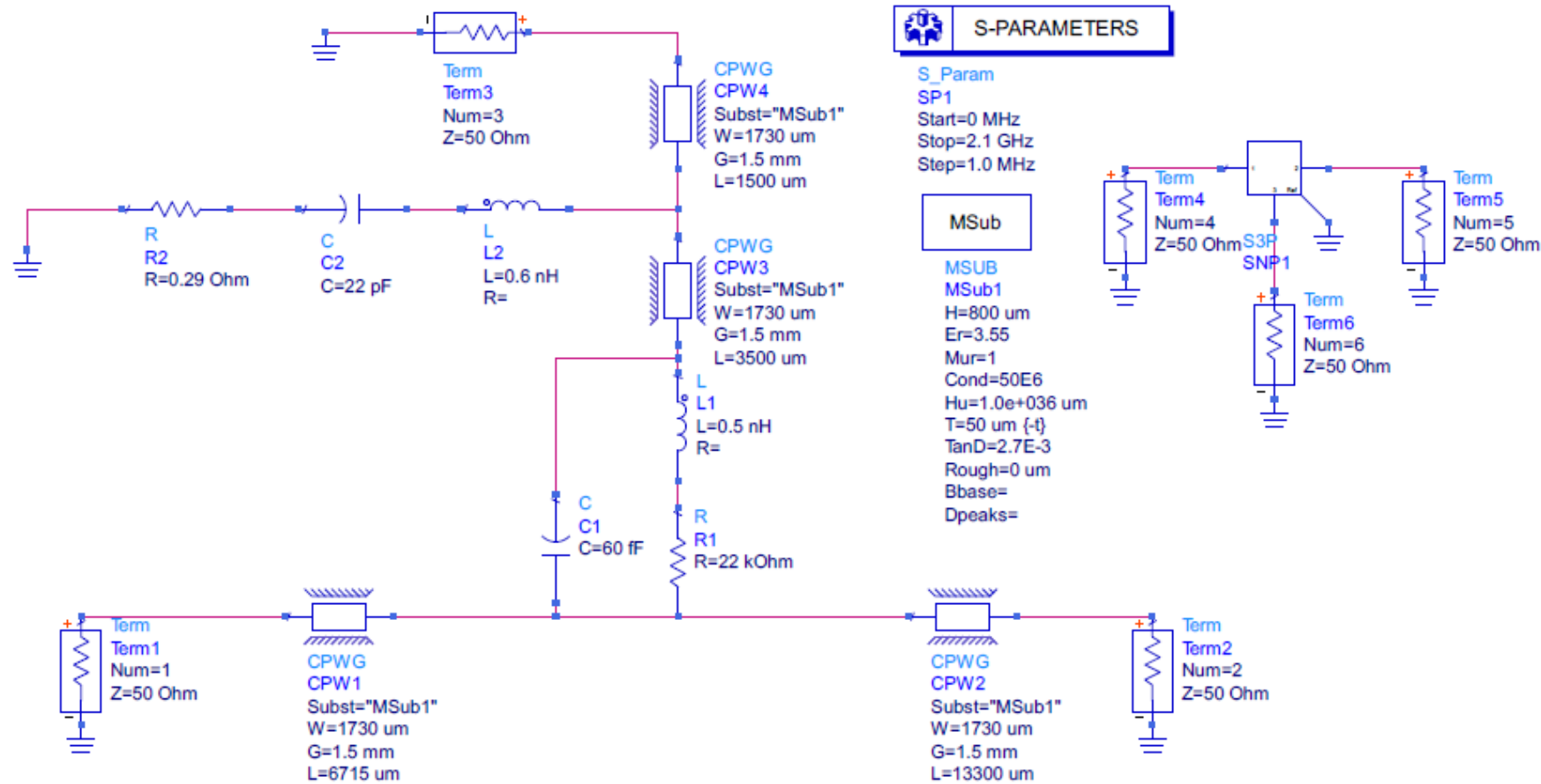

- Comparison between S-Parameters in the electromagnetic simulation and the equivalent circuit simulation

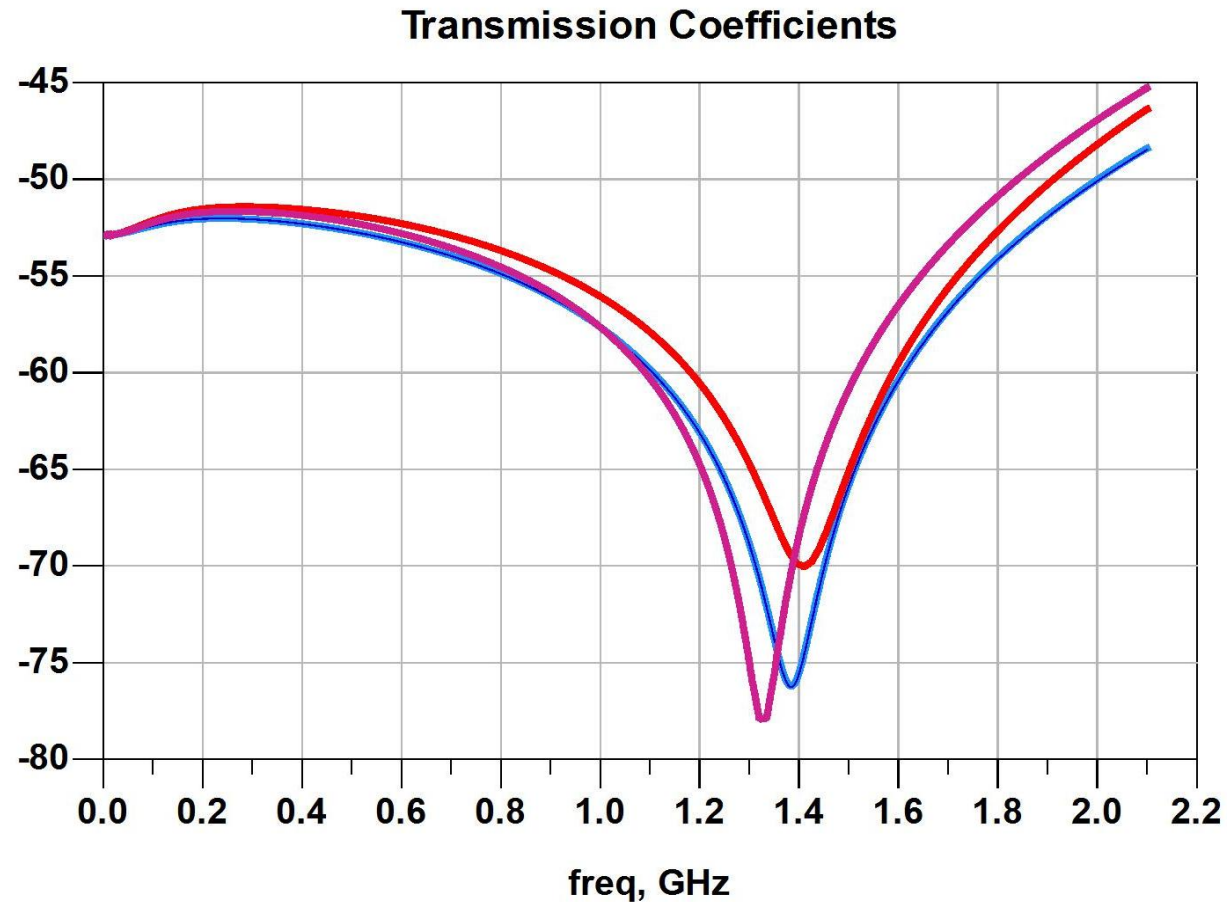

- Circuit Simulation Result
- EM Simulation Result

Induction loops in the model :

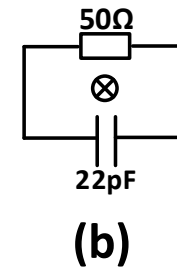
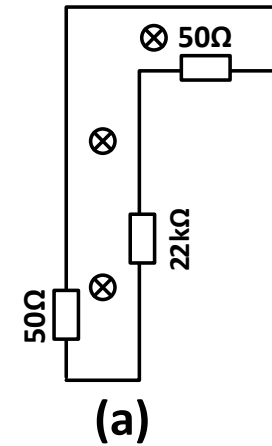
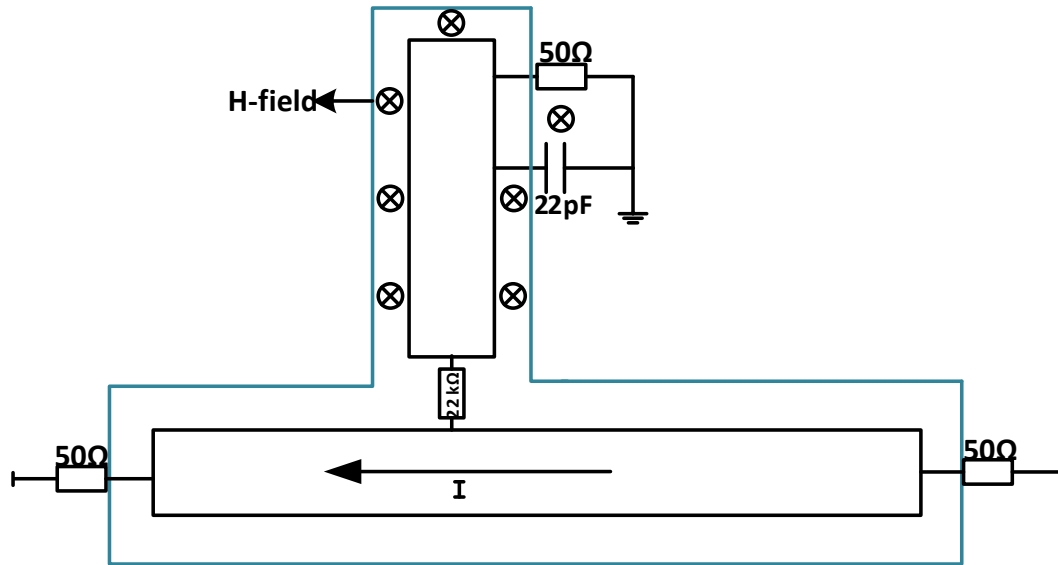

Modeling Magnetic Coupling with Transformers

T3 for loop (a)

T2 for loop (b)

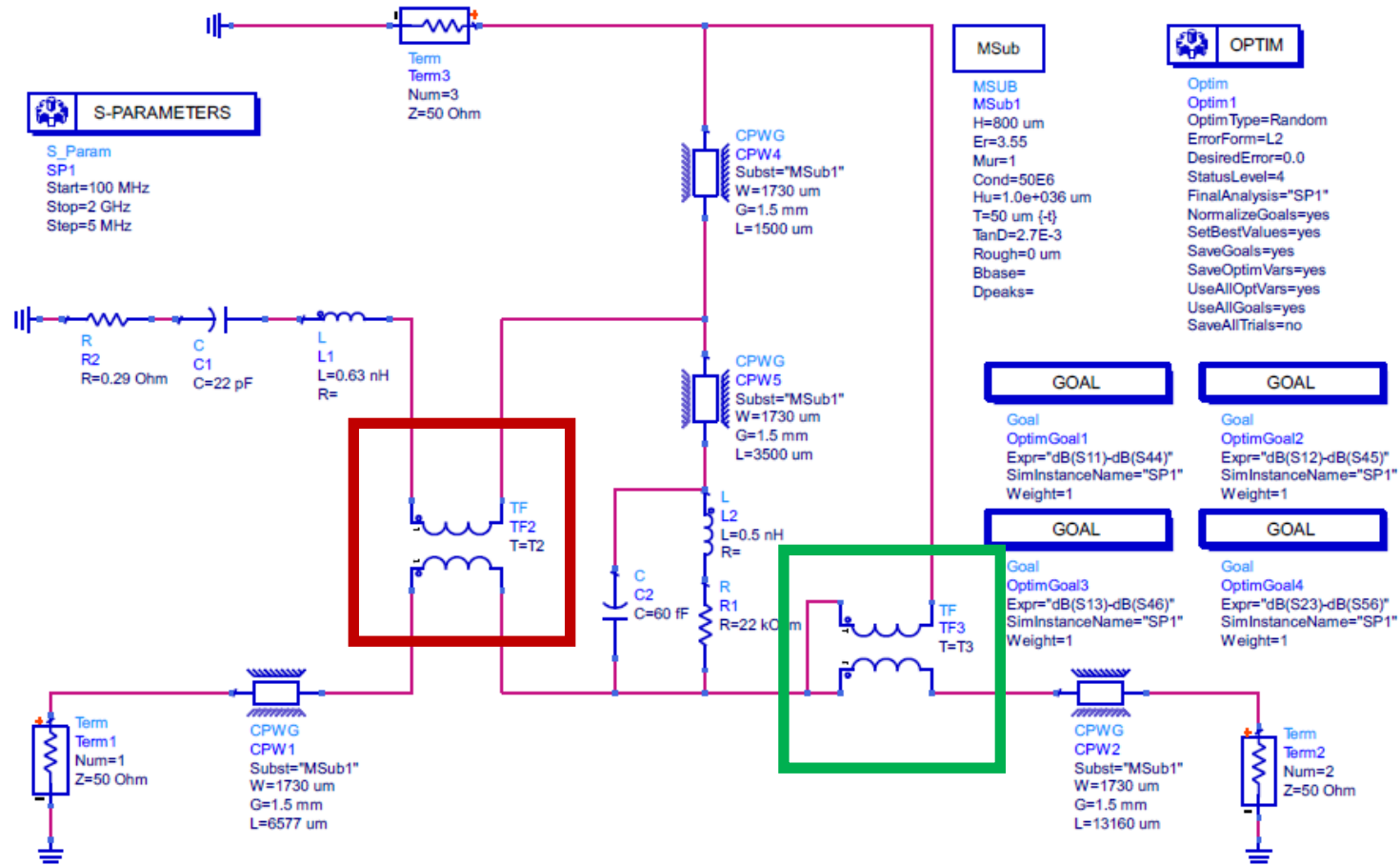

Using Coupled Inductors instead of Transformers

L3 and L6 with k2 for the induction loop (a)

L4 and L5 with k1 for the induction loop (b)

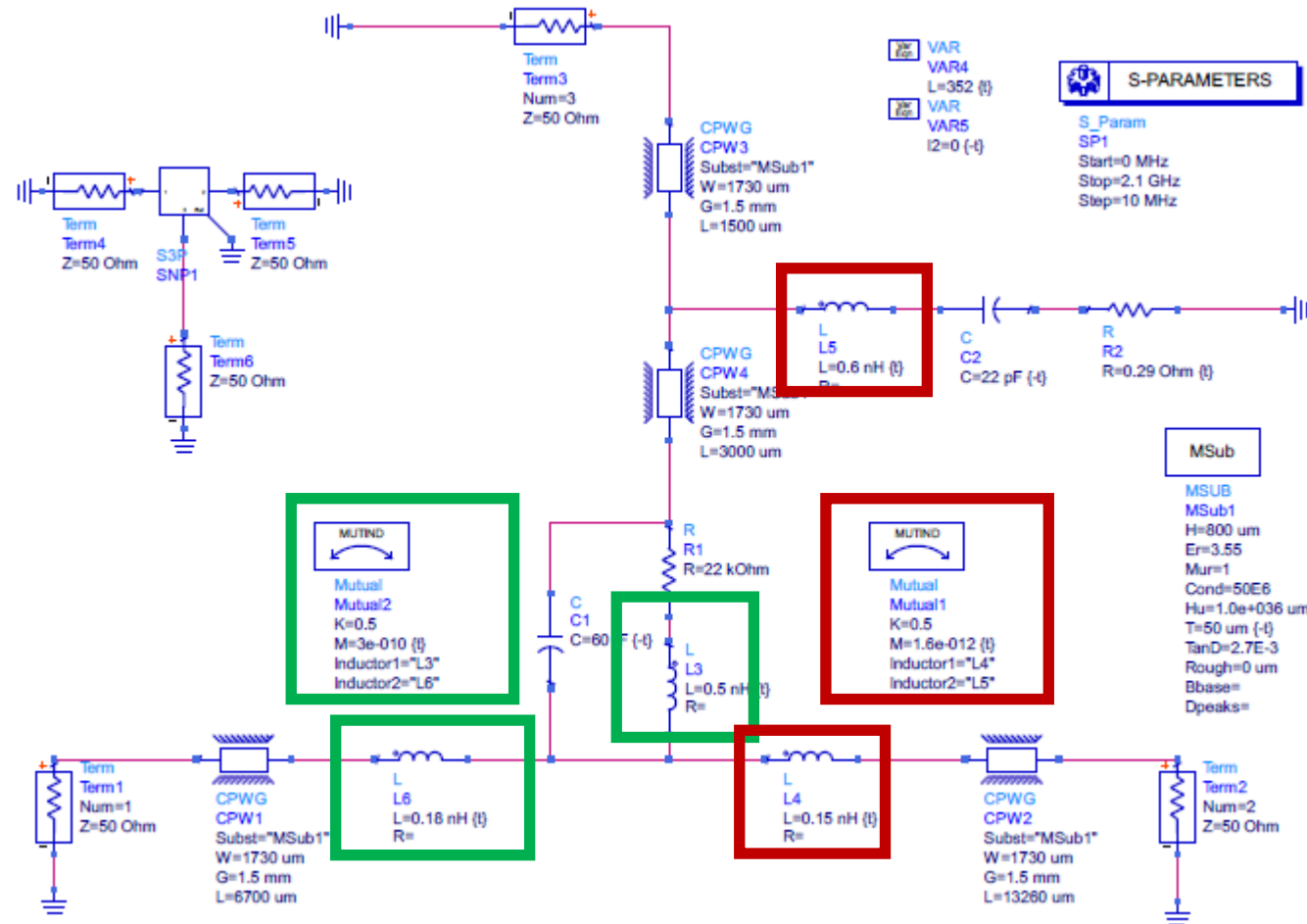

Comparison between the Results

The results after tuning the coupling factor match perfectly to the EM simulation results

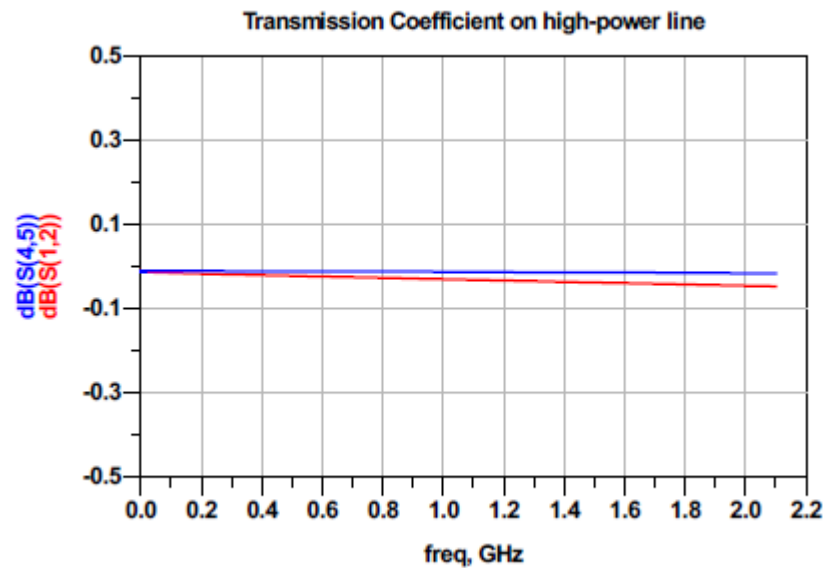

Comparison between the Results

Up to 2.1 GHz an excellent agreement between probed signal in equivalent circuit and EM model

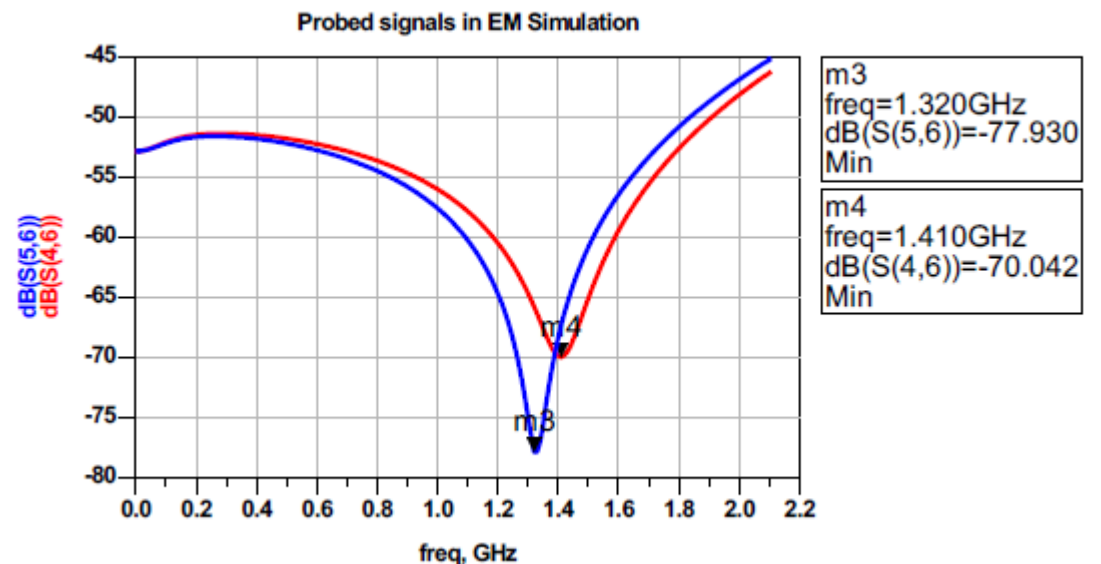
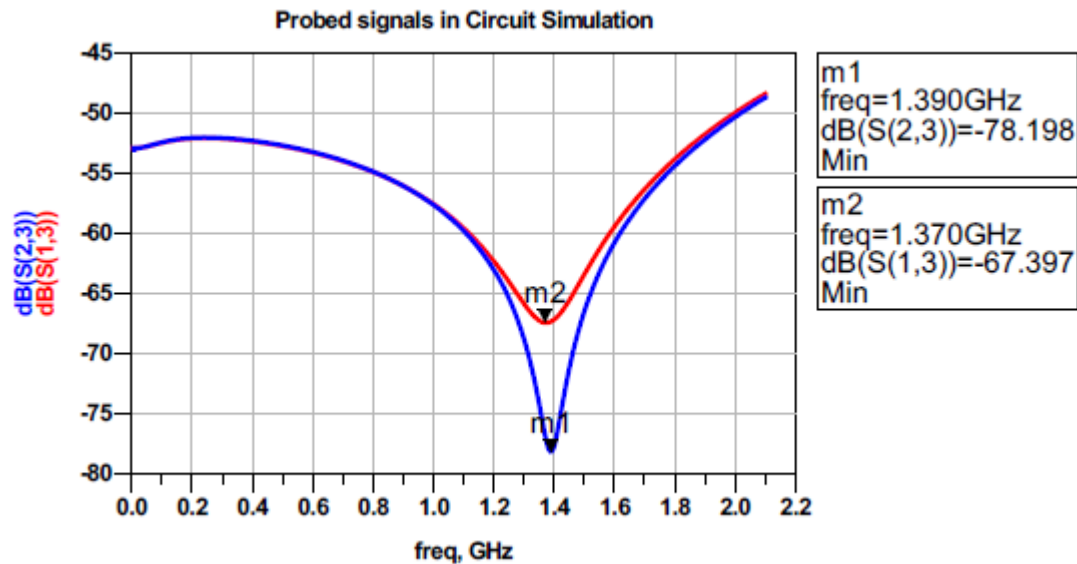

Probed Signal in Larmor Frequency

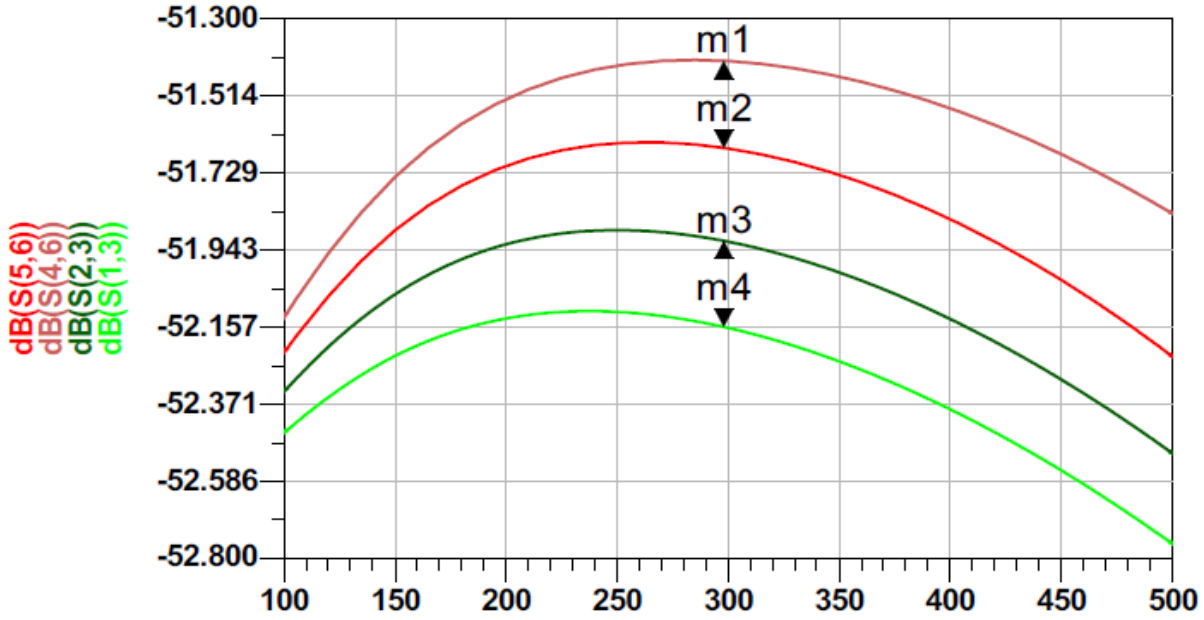

m1
ind Delta=0.000
dep Delta=0.242
Delta Mode ON

freq, MHz

m3
ind Delta=0.000
dep Delta=0.240
Delta Mode ON

m2
freq=298.0MHz
dB(S(5,6))=-51.659

m4
freq=298.0MHz
dB(S(1,3))=-52.157

- Circuit Simulation Result
- Electromagnetic Simulation Result

→ Only 0.002 dB difference!

Investigation of different coupling factors on the probed signal

Coupling Factor = k

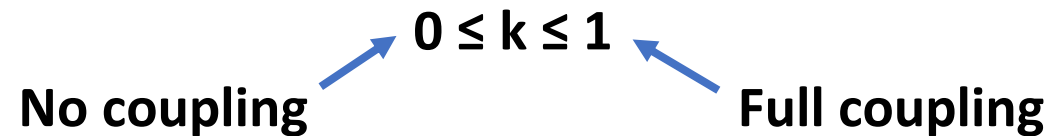

For finding the dominant induction loop , k_1 and k_2 are shifted from minimum ($k = 0$) to maximum ($k = 1$) and the effects on the probed signal in the time domain is being observed.

Induction loop (a) and corresponding coupling factor ($k_2 = 1$)

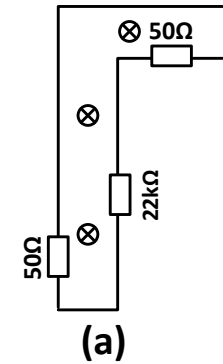
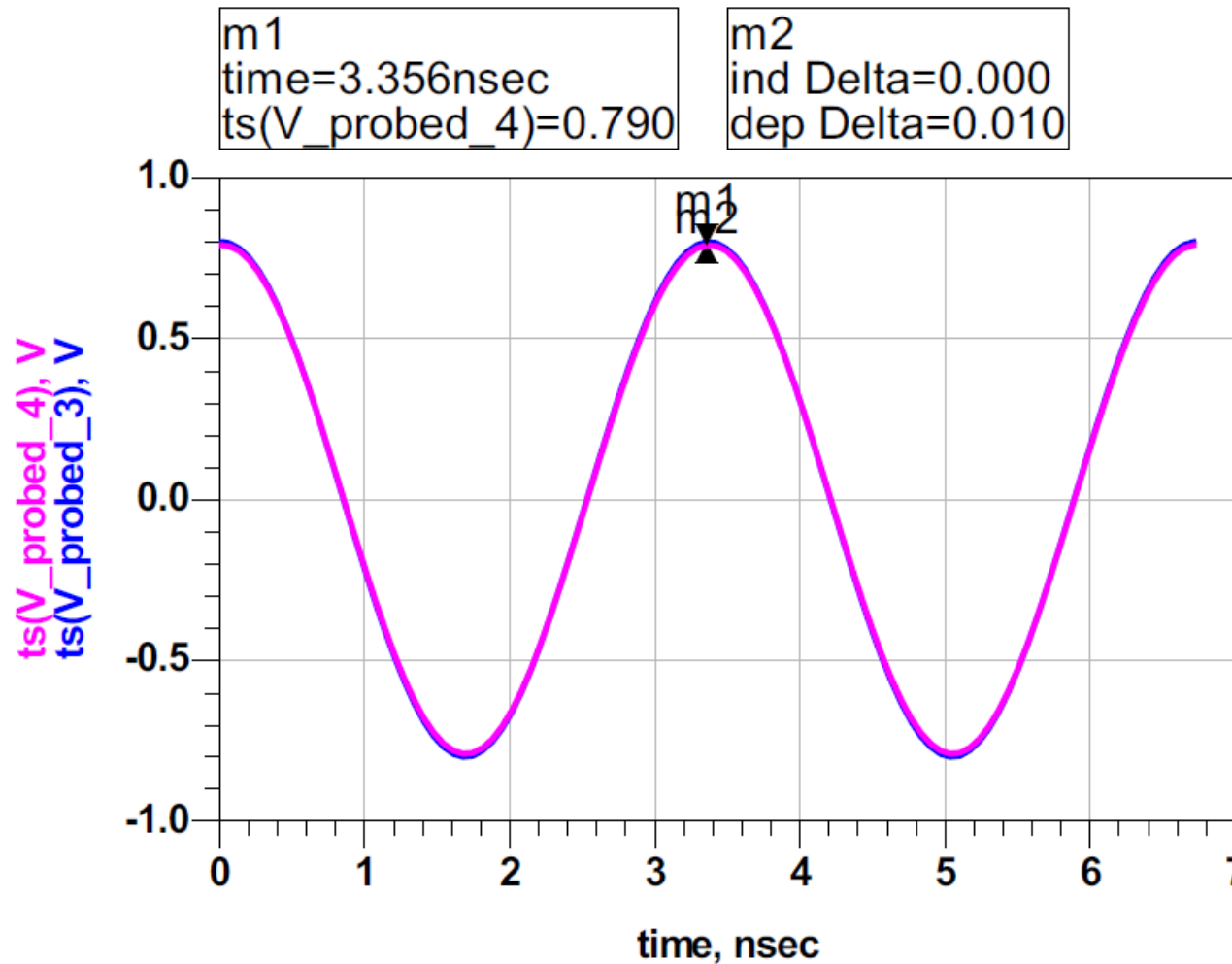

Pink Trace : $k_1 = k_2 = 0$

Blue Trace : $k_1 = 0 , k_2 = 1$

Probed Signal for Maximum Valid Value for k1

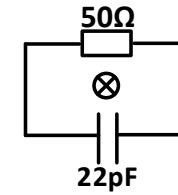
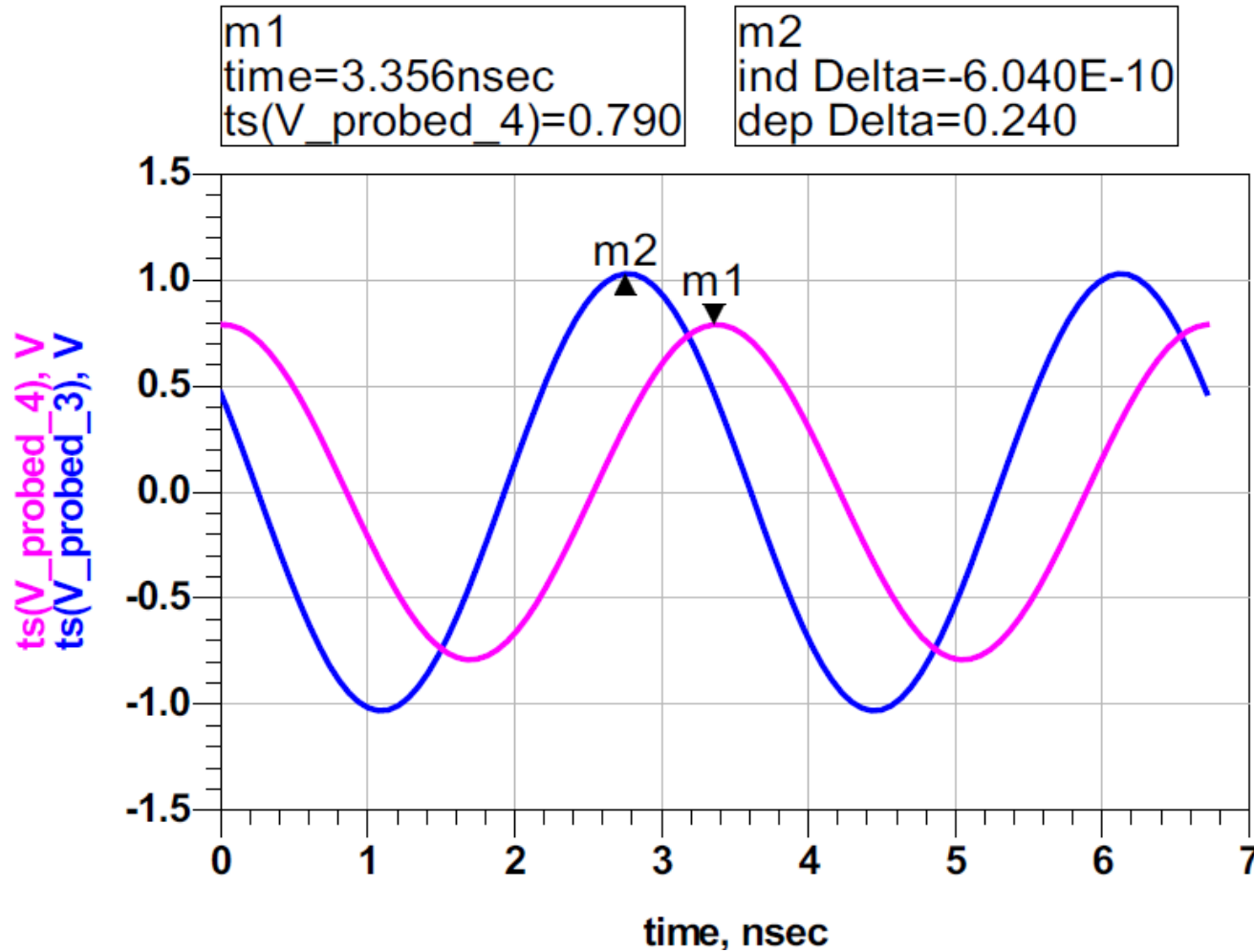

(b)

Pink Trace : $k1 = k2 = 0$

Blue Trace : $k1 = 0.32, k2 = 0$

The dominant induction loop is (b)

Some values for coupling factor on this loop and corresponding induced voltage and phase shift

K1	S23-S13 dB	Induced Voltage	Phase Shift
0	0 dB	0 mV	0 °
0.003	0.08 dB	2 mV	3 °
0.1	2 dB	40 mV	21 °
0.23	2.9 dB	79 mV	50 °
0.32	3.5 dB	240 mV	65 °

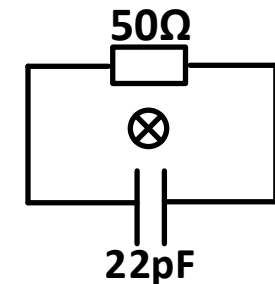

Maximum valid value for this model

Induced voltage \approx 35% ideal probed voltage

Conclusion

Equivalent circuit simulation results also showed that the induction loop which is created by shunt capacitor and coax cable is the critical area which can induce voltage up to ≈ 250 mV.

Outline

- Introduction
 - Thesis work scope
 - MRI system
 - RF Power Amplifier / Cartesian Feedback Circuit
- Inaccuracy in Probing Voltage
 - Parasitic Elements
 - Electromagnetic coupling and induced voltage
- Electromagnetic Simulation
- Circuit Simulation
- **Measurements**
- Summary and Conclusion



PCB Model for Measurements

- Measurements are done on a PCB which reflects the output part of the RF power amplifier where the voltage is probed
- PCB size = 2cm × 3cm !

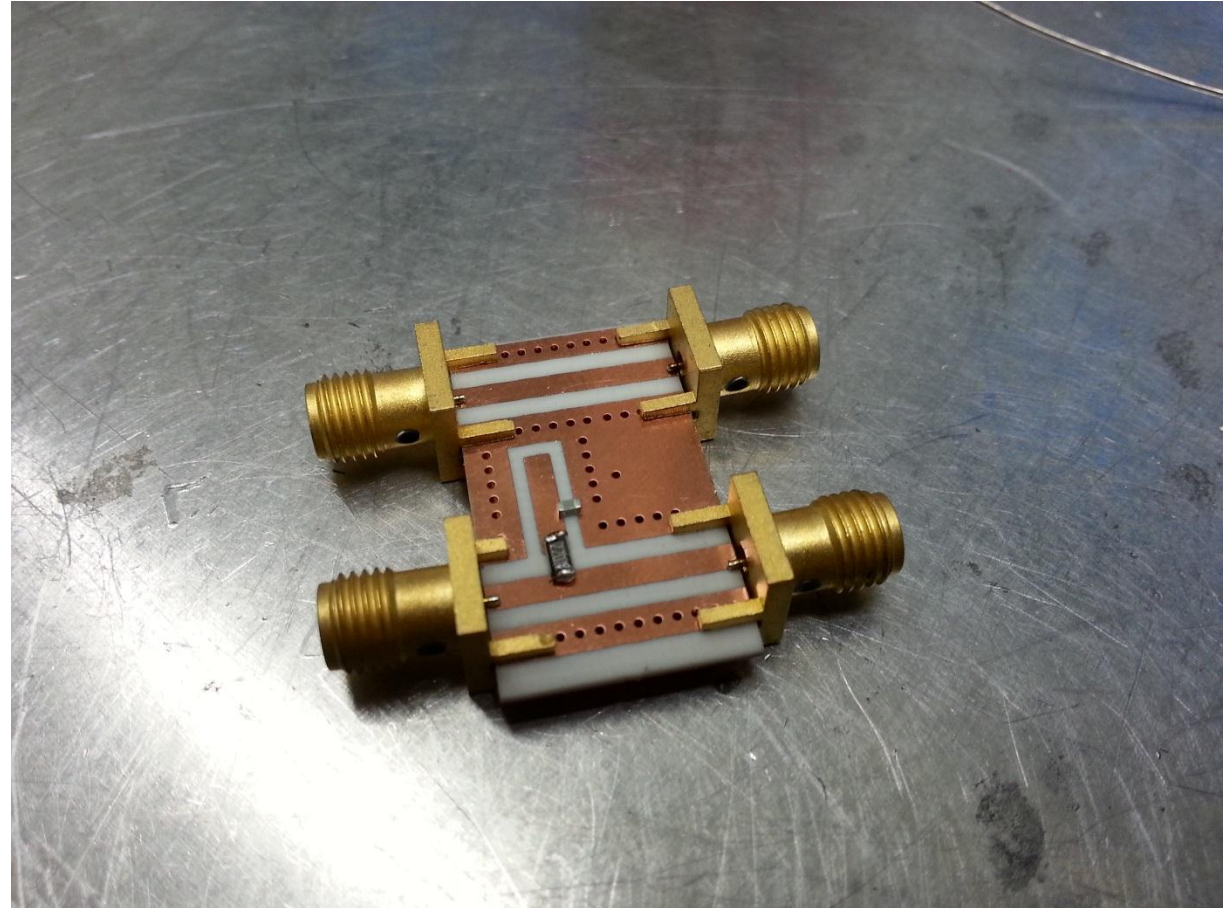

Measurement results for showing the effect of shunt capacitor

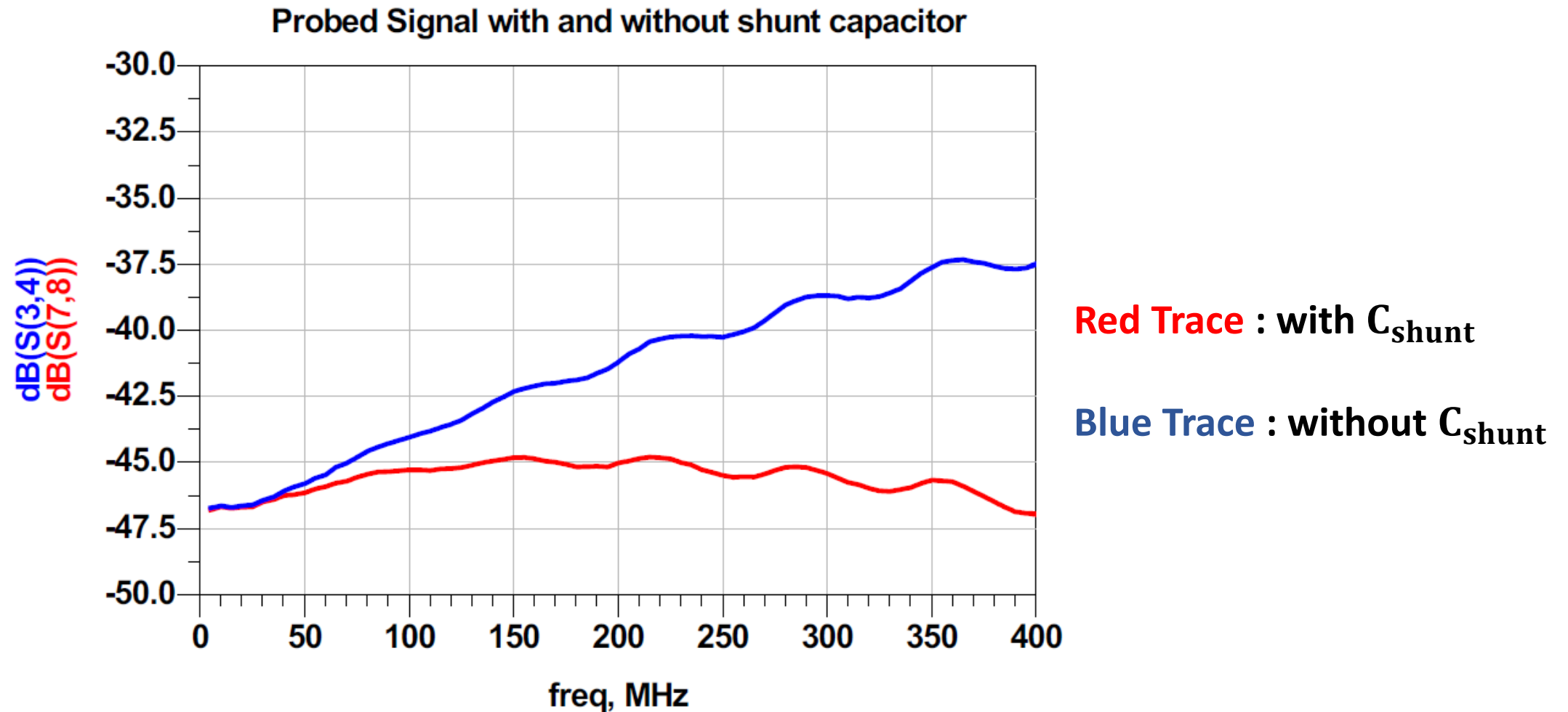

Measurement Results for Extreme Cases

- Probed signal in arrangement [1]

Amplitude and Phase deviation
for 2.7 dB difference

≈ 63 mV

≈ 35 °

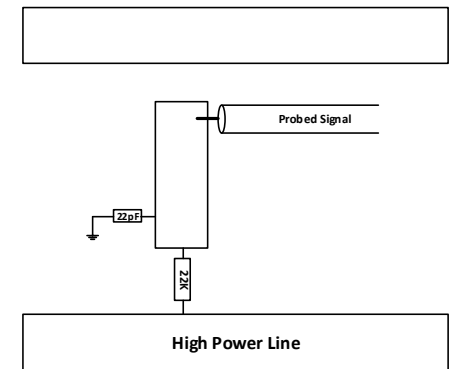
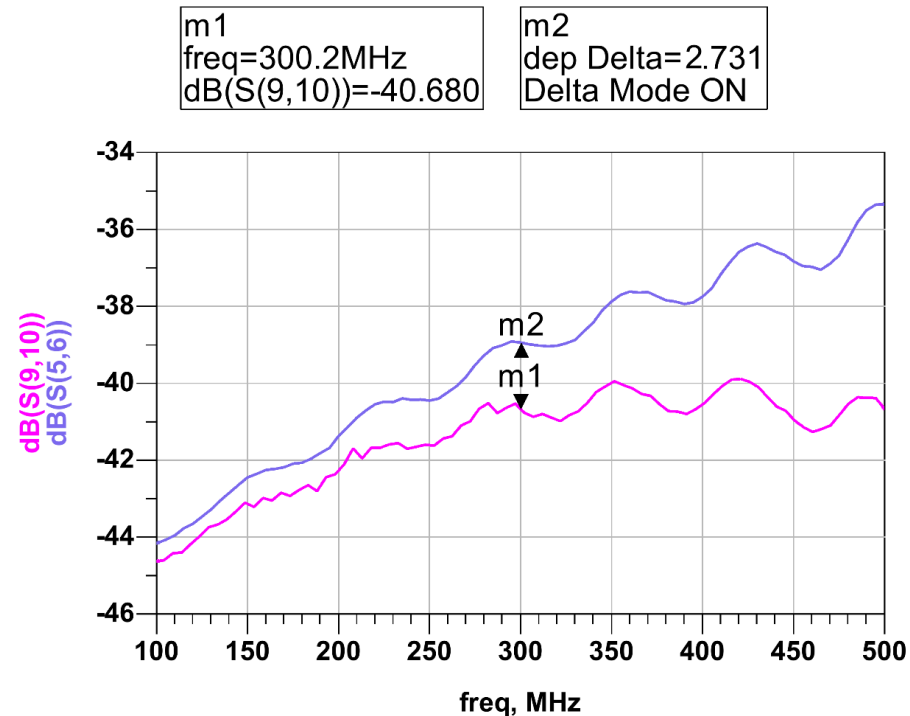

[1]

Measurement Results for Extreme Cases

- Shunt capacitor far from the coax cable

Amplitude and Phase deviation
for 1.96 dB difference

≈ 35 mV

≈ 19 °

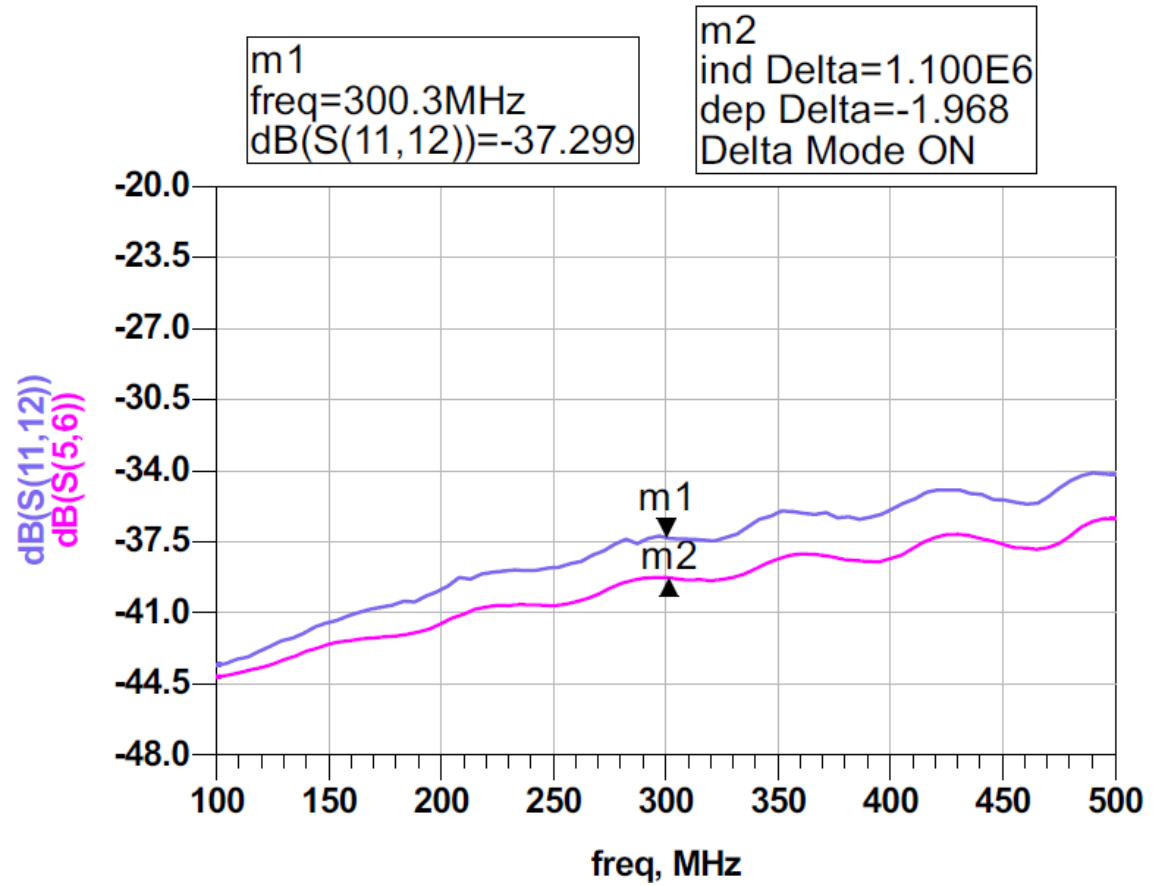

Measurement Results for Extreme Cases

- Shunt capacitor in the middle of junction and coax cable

Amplitude and Phase deviation
for 1.19 dB difference

$\approx 20 \text{ mV}$

$\approx 10^\circ$

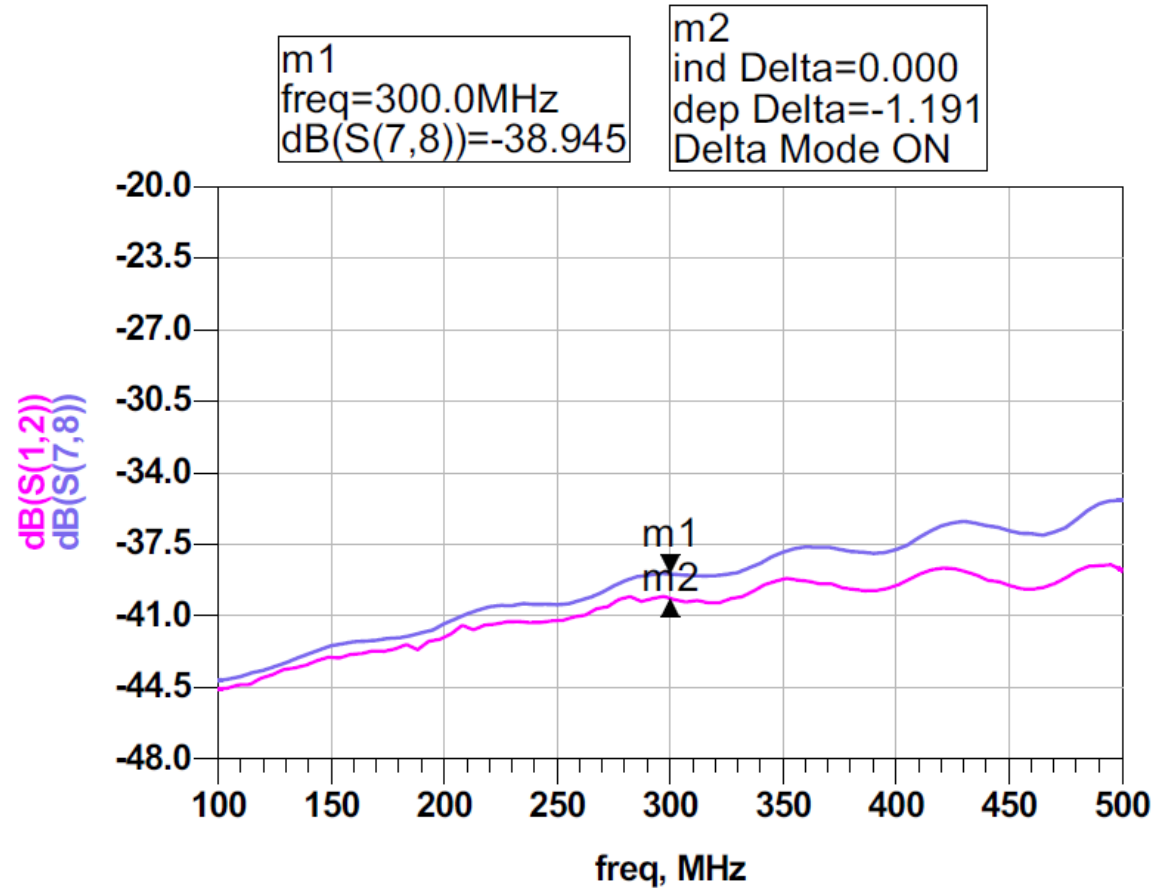

Measurement Results for Extreme Cases

- Shunt capacitor near to the coax cable

Amplitude and Phase deviation
for 0.3 dB difference

≈ 10 mV

≈ 4°

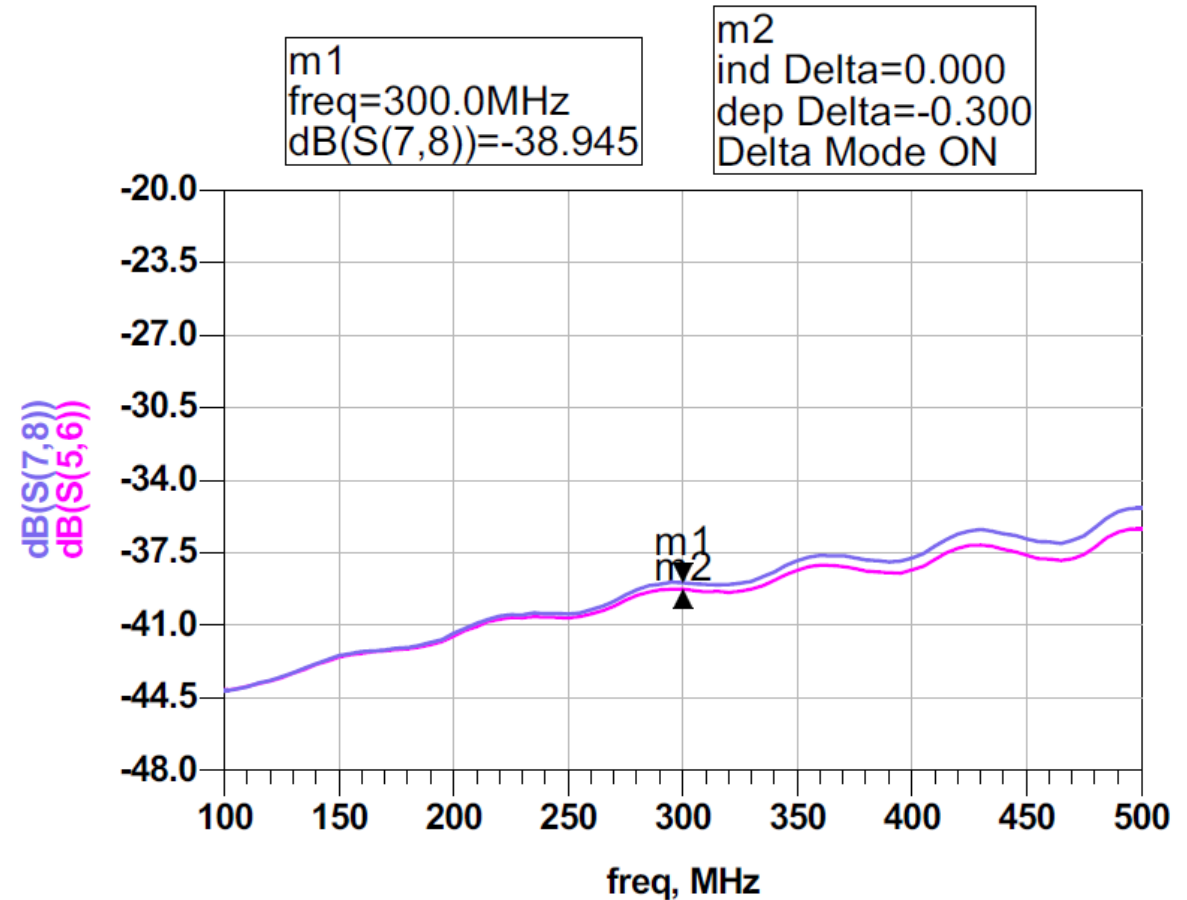

Outline

- Introduction
 - Thesis work scope
 - MRI system
 - RF Power Amplifier / Cartesian Feedback Circuit
- Inaccuracy in Probing Voltage
 - Parasitic Elements
 - Electromagnetic coupling and induced voltage
- Electromagnetic Simulation
- Circuit Simulation
- Measurements
- **Summary and Conclusion**



Summary

- In an MRI smart power amplifier, the accuracy of the probed voltage is very important.
- Magnetic coupling can induce a voltage up to ≈ 250 mV. EM simulations were done to find the best arrangement of elements for minimizing the induced voltage
- The critical induction loop which caused the most induced voltage is the loop which is created by the coax cable + a part of the transmission line + shunt capacitor
- An equivalent circuit was given for modeling the voltage probe + magnetic coupling
- Measurements were done to support the simulation results.

Conclusion

- **Electromagnetic coupling is a big concern in the probing voltage.**
- **According to Faraday's induction law, magnetic coupling can cause induced voltages on the line.**
 - **Determine the induction loops on the line on which the probed voltage travels.**
 - **Try to minimize the induction loop areas.**
 - **If possible, shift the induction loops far from the high-power lines.**
- **When needed RF shielding for minimizing the magnetic coupling and crosstalk effects.**

**Thank you for your
attention!**



Backup slides

Mismatching causes a standing wave on the high-power line

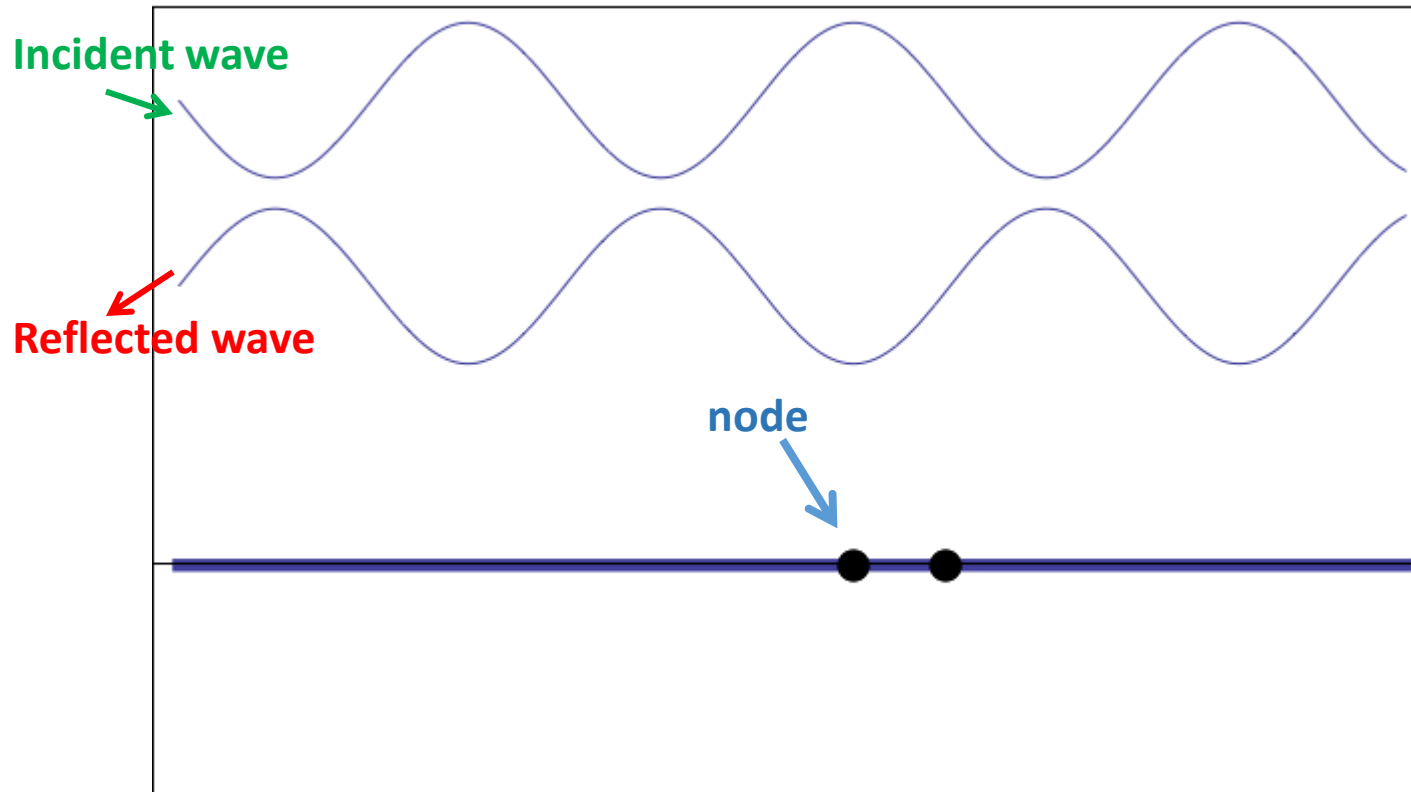

- With an open termination standing wave with node amplitude equal to 0 is expected.
- The minimum signal level that is probed is not equal to zero